

Try this: Weather house

How humidity can affect human hair to predict the weather.

Build a weather-predicting house

You'll need: A human hair, colored cardboard, scissors, screw eye, pieces of balsa wood, glue, colored pencils for cutout figures, a drill and a 1/4-inch plywood base.

1 Glue the cardboard walls of the house to the base and to each other. Glue a strip of wood between the front and back walls near the apex of the roof, with a small hole in it near the front.

2 Glue yellow pieces of cardboard around the doors. Glue the yellow design on as shown.

3 Cut out and color the cardboard figures and slide them into slots in the balsa wood swivel. Fasten the screw eye in the center and tie the hair to it.

4 Thread the other end of the hair through the hole in the crossbar above and fix with a balsa peg. The wood swivel should rotate freely.

5 Fold the cardboard roof in the middle and place it on top.

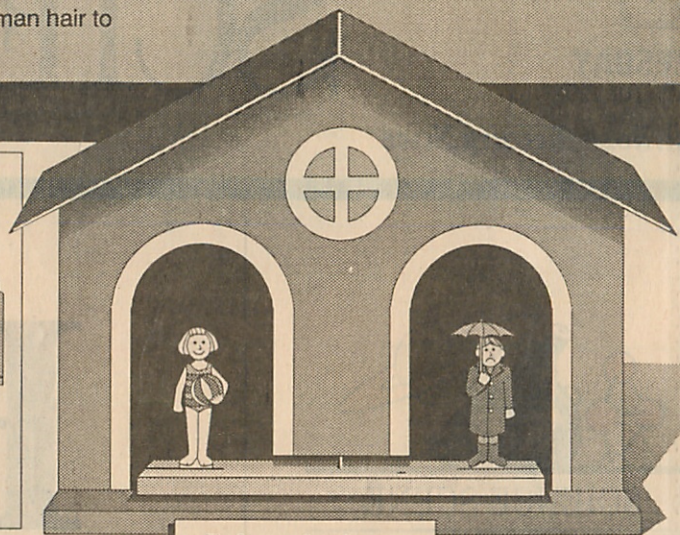
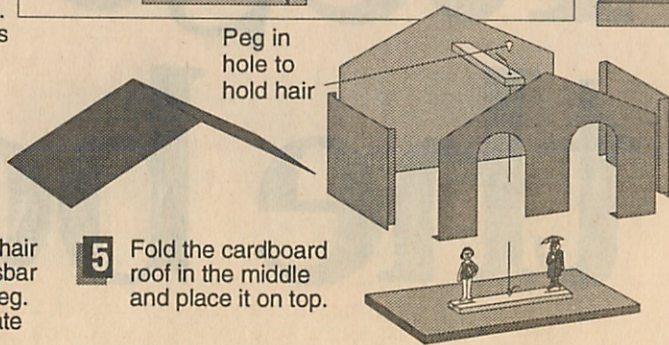
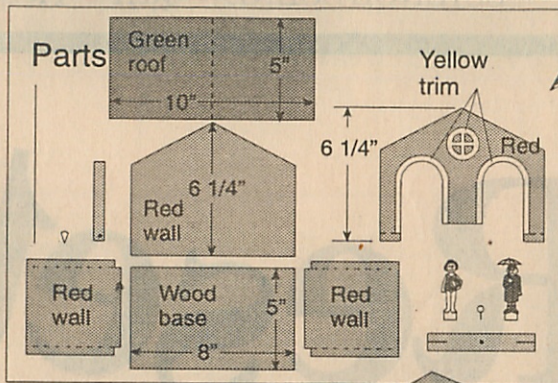

Fair or foul

If you turn the screw eye very slightly in or out of the balsa wood, you can set your weather house so that the gloomy boy with the umbrella comes out in damp weather and the smiling girl in beachwear comes out when it is dry.

What happens: The humidity in the air makes the human hair stretch; when the air is dry, the hair shrinks. This will twist the hair, and you can adjust the hair to make the right figure appear.

TRACTOR

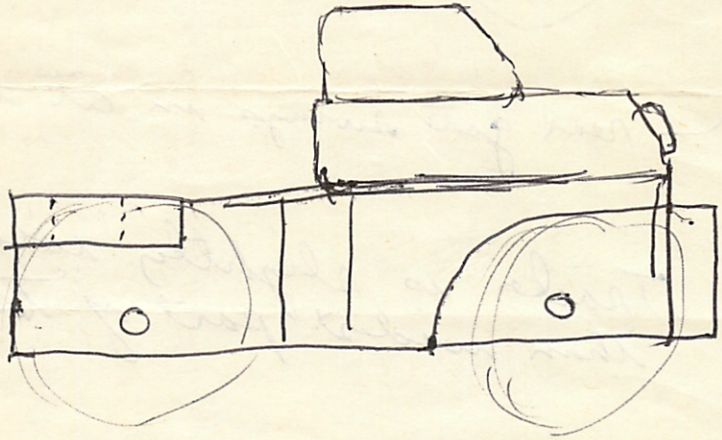
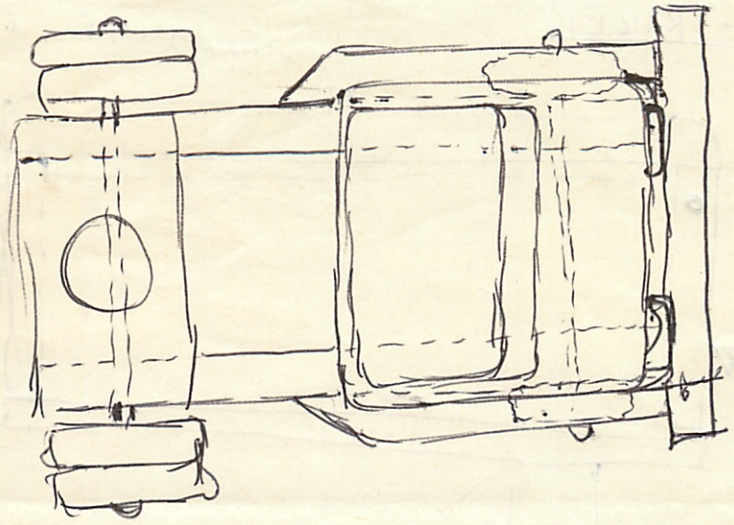

(over)

SEMI-TRAILER

removable top

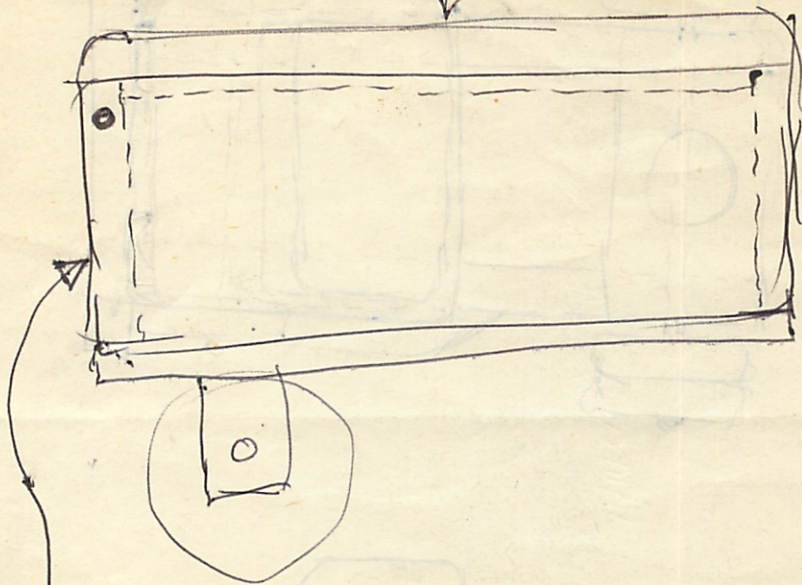

rear gate swings in at bottom

Trailer is slightly wider
than widest part of tractor

"ARIEL"—

by Hi Sibley

cents. If the smaller kite is preferred, simply scale it down in proportion to the design dimensions given here, making it three-fourths as large all around.

General dimensions are given in the drawing on page 75. These are shown without the internal twine bracing so as not to be confusing. Note that the x-braces are just half the length of the longerons, or upright side members. This applies to any box kite of



THIS very light balsa-and-tissue rectangular box kite was designed especially for MODERN MECHANIX by Ellwood Yeager, of Pasadena, Calif., a contest winner and an expert in kite construction. It is remarkably steady, and even in a very light breeze has a surprising pull.

Cost for materials was 60 cents. This is for a four-foot kite. A three-foot job would cost only 25 cents for the reason that balsa sticks jump rapidly in price above the 36-inch lengths. In other words, a three-foot hard balsa stick of one-quarter-inch section is only two cents (in the Pasadena area) while a four-foot stick costs five

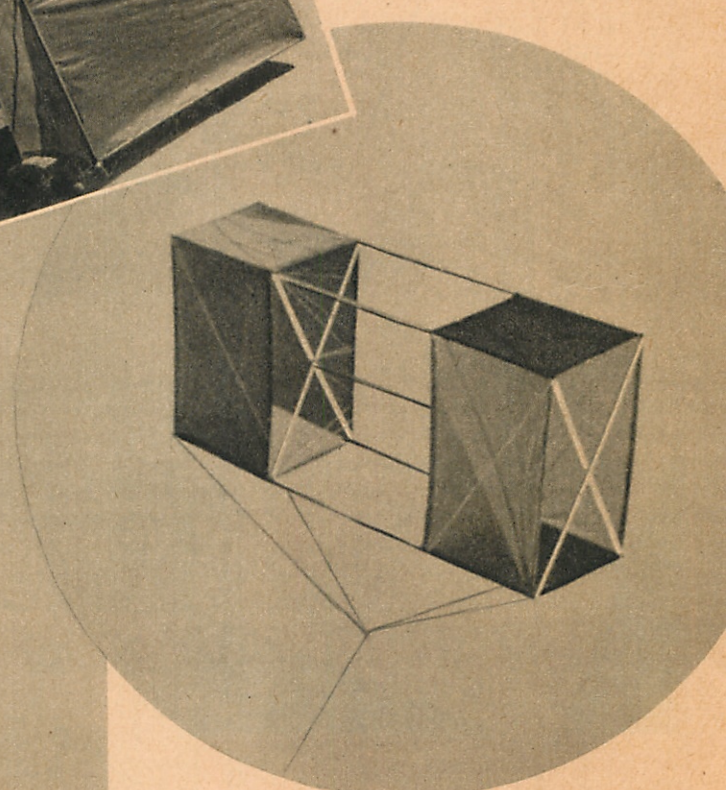

Top—Ellwood Yeager, designer of "Ariel," prepares to launch the box kite. Circle—Steady flights are the rule with "Ariel", which has a surprising pull in a light breeze.

A 4-foot Box Kite For 60 Cents

square or rectangular section. The conventional box kite is square in the end view, but "Ariel" is made rectangular and has proved to be a remarkably good flyer.

To assemble "Ariel," eight 48-inch lengths of hard balsa, $\frac{1}{4}$ -inch square are required, together with a 20-inch square piece of the same section dimensions. This latter is for the center strut. Four of the 4-foot lengths serve as longerons or corner members. Four more are cut in two to form the four x-braces.

Be sure that all x-brace members are exactly the same length and cross at the center. The end ones are then attached to the longerons, using pins and model airplane cement. Put twine around each end, draw taut, and take care that the completed job is squared off. Next install the other two x-braces, together with the center strut.

It is of greatest importance that this assembly is true, and that as little warping as possible is evident. A wooden form will be of great help in squaring up. This can be made of two wide boards nailed together at right angles, and a third one on the end. By putting the kite frame into this [Continued on page 124]

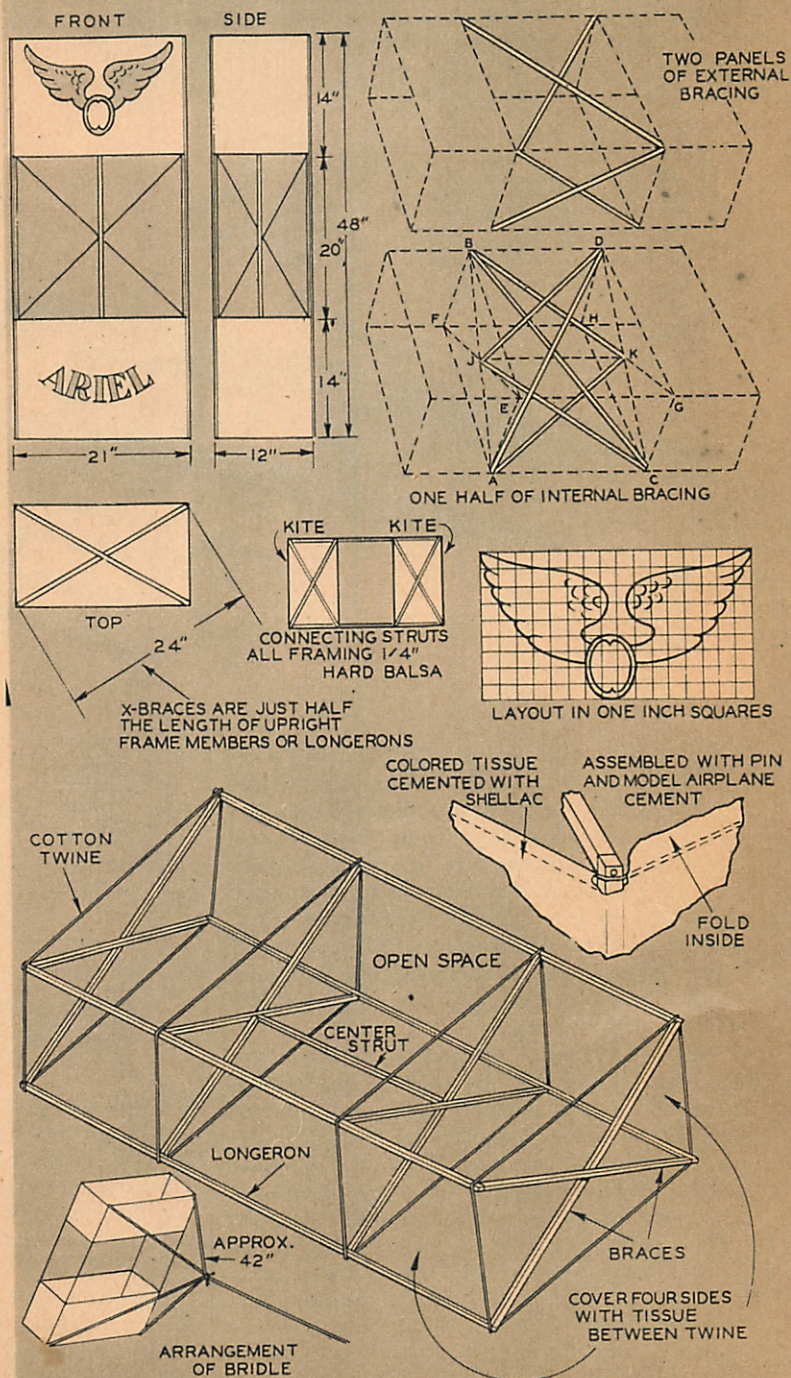

"Ariel"—A 4-foot Box Kite



[Continued from page 75]

and testing each corner any deviation can quickly be detected. This system can then be eliminated by the twine of the kite. This system of internal bracing is illustrated. Cords are strung from A to D and K; similarly from B to C and K; then from J to C and D. Duplicate bracing is strung between E F G and H. The external bracing in the open panels is also shown in the diagram, but only two panels are shown for clarity, and in both cases the strings are drawn greatly exaggerated in thickness, making it easier for you to understand the layout.

The bridle or method of attaching the control string is shown in the diagram. The point where the five strings join can be adjusted for the best angle from which to fly your kite. This will be determined by experiment.

Choice of covering material depends upon wind conditions and the sort of flying you wish to do. The original "Ariel" shown in the photos was covered with colored tissue paper, which is splendid in light winds. For stronger winds, such as prevail in the middle west, crepe paper is good, because this bags and holds the wind better than a tight paper. Put it on with the grain or creases running lengthwise.

For stunting, use cellophane, because the wind slides easily over the slick surface and permits the kite to dart about quickly. In any case do

[Continued on page 147]

WORKSHOP HOBBIES

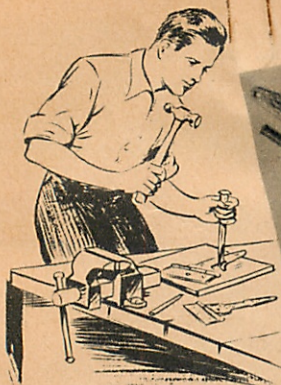

An ordinary half strap hinge can be made into an attractive wrought styled type by removing the pin and cutting it to shape with a cold chisel. A ball peen hammer is used to provide the decorative effect. Assemble hinge with butt reversed, then paint it a dull black.

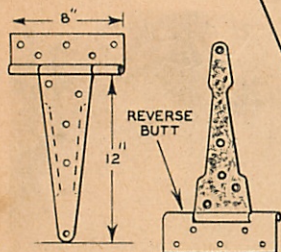

WROUGHT IRON HINGE

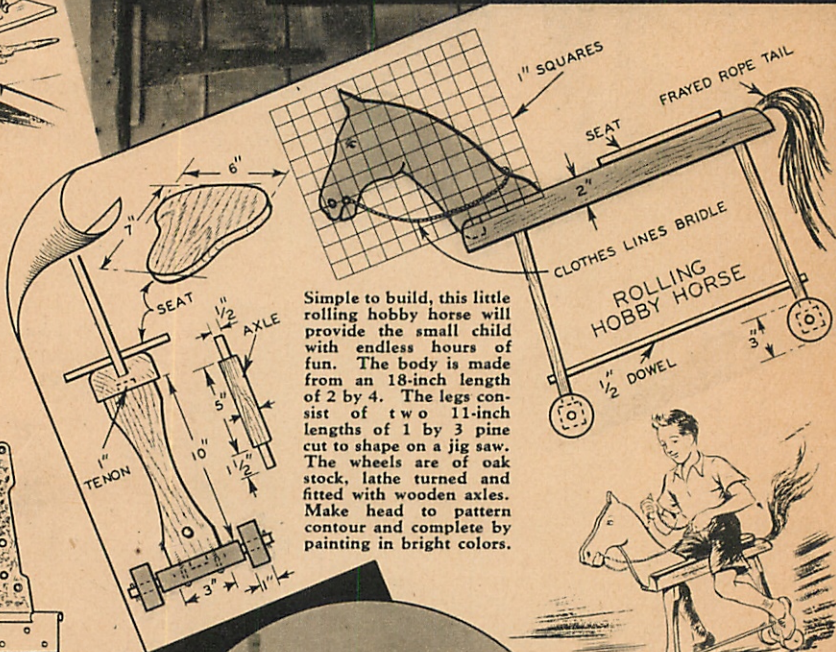

Simple to build, this little rolling hobby horse will provide the small child with endless hours of fun. The body is made from an 18-inch length of 2 by 4. The legs consist of two 11-inch lengths of 1 by 3 pine cut to shape on a jig saw. The wheels are of oak stock, lathe turned and fitted with wooden axles. Make head to pattern and complete by painting in bright colors.

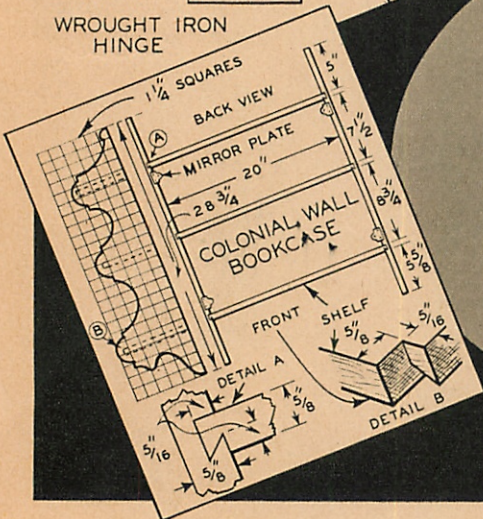
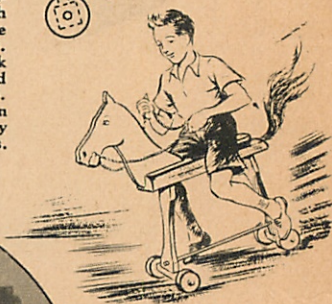

A Colonial wall bookcase constructed like the one pictured above makes a useful and attractive home decoration. Cut the sides from 3/8-inch maple, 28 3/4 inches long and 7 1/2 inches wide to the scroll pattern shown. Joint the 3/8-inch shelves to sides and glue. Last, finish with one or two coats of varnish.

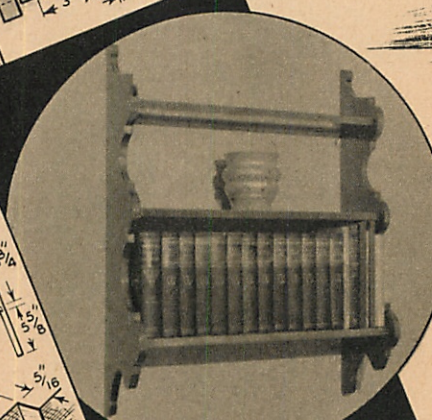

A ship smoker, like the one described below, makes a novel nautical decoration for the den. Shape the hull from a 20-inch block of walnut. The deck, ash trays and turrets are of maple, carved or lathe turned as the case may require. Walnut parts are stained, while the maple finish is treated only with wax so as to obtain a high lustre. If a smaller smoker is desired, the dimensions may be altered accordingly.

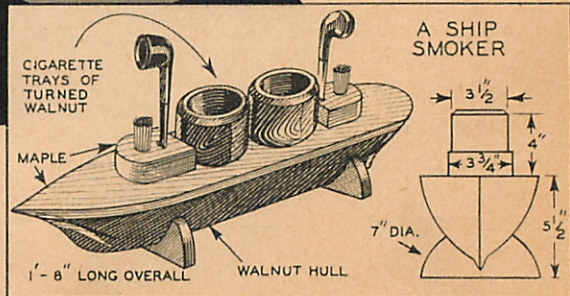

He made his lamp with rough-sawn pecky cedar

The cedar jackets described in *Thin jackets for plants in homely cans* (June 1973 *Sunset*, page 128) appealed to reader Ted Haldeman of Saratoga, California. First he made several as planters. Then he decided to apply the same basic construction to create the unusual lamp pictured at right.

Shade-top and base sections are made from 1 by 12 rough-sawn pecky cedar. Sixteen 1-inch-thick aluminum tubes (available at hardware stores), each 18 inches long, separate the two sections.

In the base section, holes drilled through an acrylic plastic plate and halfway into a particle board plate hold the tubes in position. Pieces of 3/4-inch doweling hidden inside the four corner tubes are screwed to the plastic plate in the shade section and the particle board below to lock the two sections together. As the

drawing below shows, the top plastic plate has an octagon cutout.

The electric cord runs up one of the aluminum tubes and is wired to a light socket suspended in a wire frame. The wood shade lets light escape only above and below it, except where the peck holes go clear through the boards.

Materials cost about \$25. □

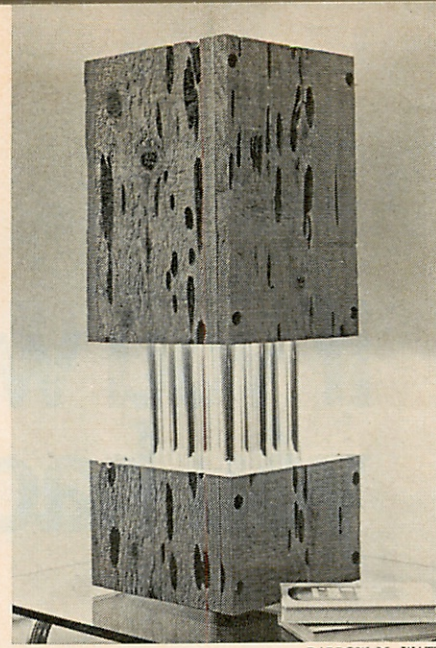

DARROW M. WATT

Rough cedar sections seem to float above and below polished aluminum tubes

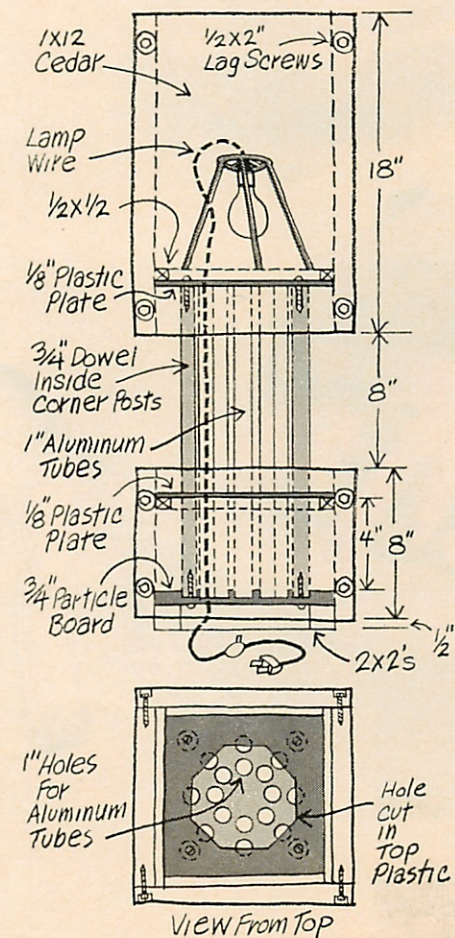

Used to be, if you wanted a good lunch, you had to have a big lunch.



ONE-WEEKEND PROJECT
 \$200
 DESIGN
 AWARD
 COMPETITION

FINAL MONTHLY
 WINNER

P. Favot
 of Pittsburgh, Pa.



Stable, stylish little rocker is made of five interlocking pieces of plywood.

Snap-together rocker for kids

A quarter sheet of half-inch birch plywood and a saber saw are all you need to build our final Weekend Project. No need for nails, glue, or screws—the little rocker just snaps together.

The designer used birch plywood because its edges are much

more splinter-resistant than fir ply. After cutting all the parts to shape, sand all exposed edges—but not the locking edges—to a smooth, even radius. Finish? A bright lead-free enamel or a couple coats of varnish provide plenty of protection. **ES**

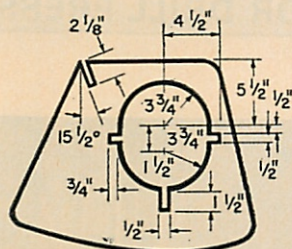

SIDE PIECES (2)

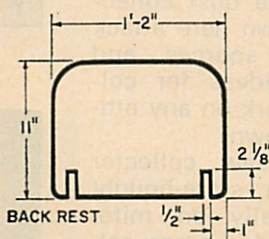

BACK REST

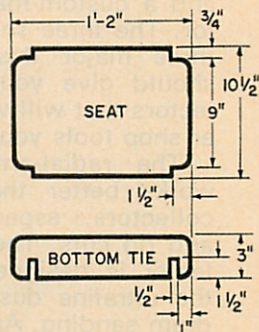

SEAT

BOTTOM TIE

NOTE:
 ALL PIECES CUT
 FROM 1/2" BIRCH PLYWOOD

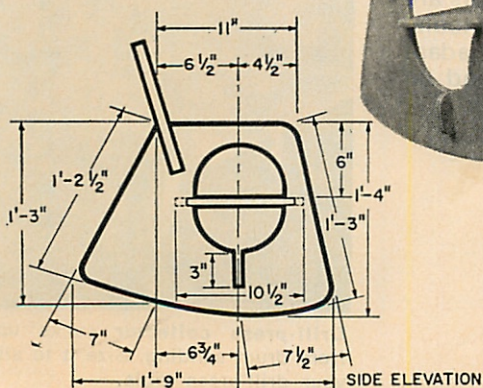
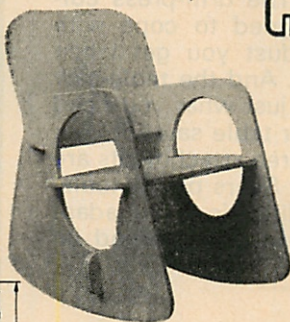

SIDE ELEVATION

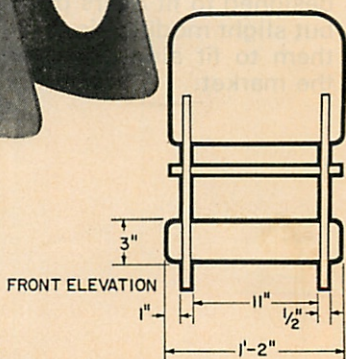

FRONT ELEVATION

724-7566



New Life for a Pair

Whether you make them for decoration or functional play,

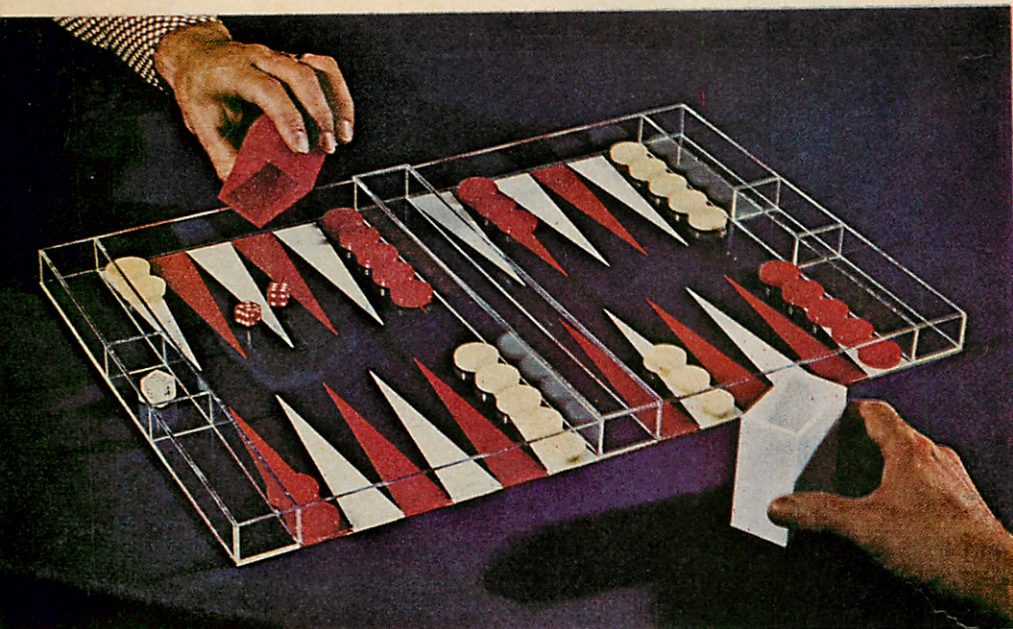

SEE-THROUGH BACKGAMMON BOARD

The ancient game of backgammon—a current rage again—looks great in modern dress. It's all Plexiglas, right down to the dice cups. Here's how to make it:

Cut all pieces and sand out saw marks with number-80 paper on a block. Study the sketch at right. All exposed edges should be polished to

YOUR PICK OF APPALACHIAN



The Appalachian-mountain dulcimer, known for its delicate, charming sound and simple strumming, is as easy to make as it is to play. Unlike other instruments that have evolved into formal patterns, the dulcimer is still designed largely by its builder. Wood for the body and fretboard should be straight-grained, clear, and quarter-sawed.

The pattern and mold. Fold a large piece of paper in half lengthwise and mark the fretboard length along the fold with two lines extending half the desired fretboard width. Connect the ends of these marks with a graceful, curved line for the final body shape. That shape is up to you. The traditional patterns here, by Appalachian craftsmen David Hoffman (walnut teardrop) and Jene Hughes (spruce hourglass), were formed by bending a narrow slat (already cut for use as one of the body sides) and tracing its curve.

Cut through both halves of the paper and unfold your pattern. Transfer the shape to a flat board and use blocks of wood and angle

of Old Favorites

here are two fun items enjoying a mod revival

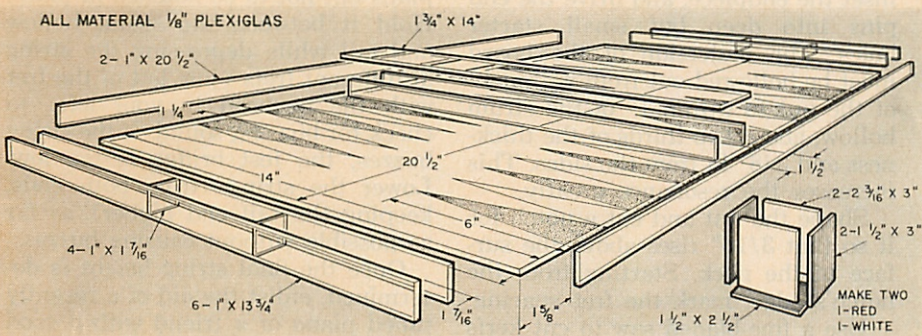

transparency. To do this, resand with 220 paper, then switch to 320 waterproof paper used wet. After that, turn to 400 paper—also used wet—and finally polish with automotive rubbing compound on a rag.

Now lay out the arrows on the bottom of base piece. Draw them right on the masking sheet. Use an X-acto

or razor blade to cut out the red arrows. Peel off the mask for the red arrows and spray the exposed surface with an acrylic lacquer. Four or five light coats 20 minutes apart will do the trick. Tape the edges of the base to mask from overspray.

Now cut and strip the masking from the white arrows. Spray as be-

fore. Give the red arrows a coat or two of white, too.

After the lacquer has dried a good 24 hours, cement the board together. Use masking tape to hold the parts while you apply a solvent cement on all butt joints. Use the same procedure to cement up the dice cups—simple 2"-by-3"-by-3" boxes. When assembly is complete, wash the board with detergent and warm water.

Since our board is for display, we've made no provision for foldup storage. You buy the red and white "men." A checkers set won't do since it has only 12 of each color. Backgammon calls for 15 each.

Need further instructions? A plans sheet including a full-size layout of the arrows is available for 50¢. Send to: Projects of Plexiglas, Box 14619, Philadelphia, Pa. 19134, and ask for No. 52. P 5

DULCIMERS

brackets with bolts to complete the mold. At points where the sides curve in, align the blocks with the edge of the pattern; where the sides curve out, set in the blocks to allow for the thickness of the side slats.

Fashioning the peghead. It may be either plain or carved, as shown. The part of the peghead that is to be glued inside the dulcimer must be notched and tapered so the body sides join flush with the peghead's exposed portion. The final shape here

must match the corresponding part of the mold, less the thickness of the sides. If necessary, use scrap wood to increase the angle. Complete the peghead by drilling and tapering holes for the tuning pegs.

Tail block and sides. The tail block is fitted by again using the mold to determine the shape. It should be made 1/16" lower than the width of the sides so that in the final assembly there will be an open-

Continued

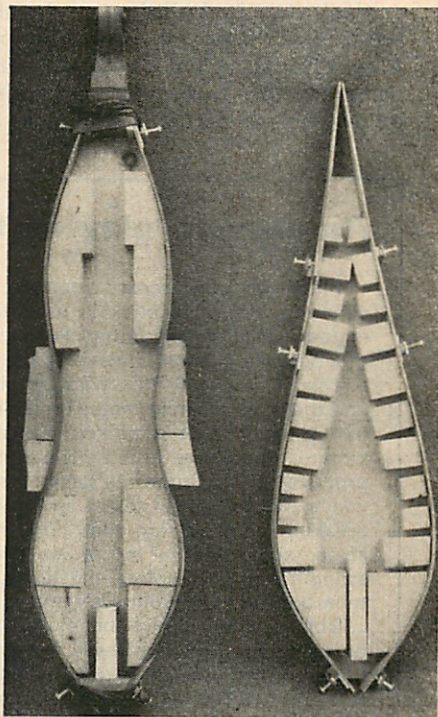
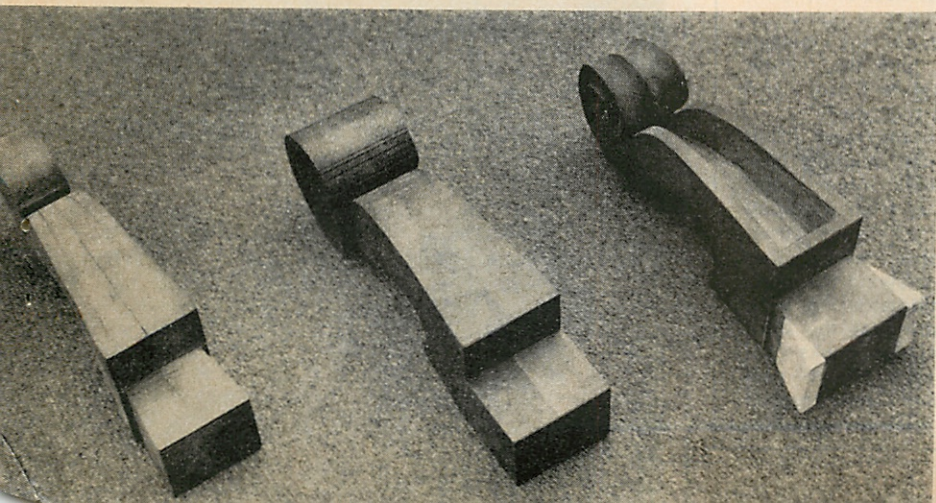

Mold for curved sides is made of blocks of wood held in place with bolts and angle brackets. Build it on a base of pine or plywood. Scroll peghead is a challenge in wood carving. Block at far left is for a plain scroll. Center block is for a carved scroll like the one nearly completed beside it.

The dulcimer is still largely designed by its builder. Each one has

ing between it and the top through which the sound may escape.

The side slats must be clamped together and carefully planed so that both edges are straight and parallel. Then they should be weighted and submersed in water for 12 hours and clamped in the mold for a full day. Square and cut off excess at the peghead end and test the head and tail blocks for fit. Adjust as necessary for a tight joint and, using wrappings or inner-tube rubber for clamps, glue sides to peghead and tail block upside down. Since the tail block is smaller, it must be shimmed up to be flush with the upper edge of the sides as they rest in the mold. Trim excess length from the sides after glue has set.

The bottom. Check that the side assembly has not twisted in the mold by sighting a straight line from head to tail. The bottom piece is marked by holding it in place and tracing around the sides from underneath. Saw out the piece, staying to the outside of the lines and glue in place, again using wrapping of rubber for clamps. When dry, remove it from the mold and reinforce with small triangular blocks of scrap pine and bottom braces as shown.

The fretboard. This is the most critical step in building a playable instrument. Plane the top and bottom surfaces as flat as possible and complete the flattening by sanding on several sheets of sandpaper, ce-

mented end-to-end on a flat board. A twisted fretboard or one bowed up in the middle will render the instrument unplayable, while a slight downward bow in the middle is acceptable. Cut out the strum hollow, inset the endpiece, and drive the end pins into deep but small starter holes. The underside of the board must be hollowed out from within 1" of the nut to within 1" of the strum hollow, about two-thirds of the thickness and 3/8" in from the sides. This increases the resonance greatly.

Shape the nut and cut a notch for it so that 3/16" rises above the surface of the neck. Starting from the notch's edge, mark the fret spacing.

Use a fine-bladed saw to cut kerfs for the frets, and drive the barbed edge of the fret wire into the slot. Each fret should be left a little long, filed off, then sanded with emery cloth to insure smoothness.

The top. This is marked to fit the bottom assembly and sawed, leaving some excess to trim later. The sound holes (any shape, attractively placed) are sawed out and an opening is cut to match the hollow underside of the fretboard. This opening is broken to allow for the cross brace. Align the top and fretboard neck on the bottom assembly and lightly mark the position on the top. Apply glue to the fretboard, and join to the top with small wire brads from the underside.

Final assembly. Glue together top and bottom assemblies, using

clamps. Next, glue the nut in place and file shallow grooves for the strings. Fit the tuning pegs in their holes, wind on one of the double melody strings, and make a test bridge—shaped like the one in the plans but not to be notched in place. Hold it between the strum hollow and tail while depressing the string at different frets (just left of the fret with the peghead to your left) to check for buzzing sound. If the string buzzes, the test bridge is too low. Lower the string (from both ends, keeping the tail end higher) as far as possible without causing buzzes.

Once the final string height is determined, enlist the aid of a recently tuned piano or a friend with a good ear for pitch. The open (unfretted) string must sound one octave higher when fretted at the eighth fret (when singing *do re mi fa sol la ti do*, the two *dos* are one octave apart—the distance between any eight white keys on a piano). If the note at the eighth fret sounds too high, move the test bridge toward the tail, and vice versa. Repeat this process with the bass string (this end of the notch will be closer to the tail).

Once well-tuned octaves are found, mark the location and saw the notch for the permanent bridge, which must be sized so the string height is identical to that of the test bridge used. Sand the dulcimer and finish with gunstock oil (not linseed) and cabinetmaker's wax. P 3

As easy to play as to make

Place dulcimer across your lap with the peghead to your left. A noting stick is used to depress the double melody strings (the other two just drone). Don't lift this noter to change notes—slide it while your right hand strums with a quill, thin wire, or piece of plastic jug. To find the most resonant notes for tuning, hum up and down into a sound hole until you feel the dulcimer ring and vibrate. There are usually two different notes that will produce this, so tune the bass string farthest away from you to one of these notes, taking care not to tighten to breaking point. Using that note as *do* of the musical scale, sing, "*do re mi fa sol*," and tune the middle string to *sol*. Complete the scale, "*sol la ti do*," and tune both of the melody strings to the high *do*.

This scale can now be played from the open string by using the noter on each fret in order, skipping only the sixth fret (which is used when a dark, minor sound is desired). The right hand strums away from the body with the words of the song, and a quick return strum adds variety. Try using the return strum every other time. The art of dulcimer playing is in knowing the many tuning methods: Try lowering the middle string from *sol* to *fa*, and fretting the melody string at the third fret to produce *do*, for example. Instruction books give other tunings. Dulcimers can be picked like banjos, strummed like guitars, bowed like fiddles.—Jene Hughes

Violin-style carved scroll with hardwood tuning pegs is more traditional, but the guitar-style peghead is easier to make, and the metal tuning keys work much more smoothly.

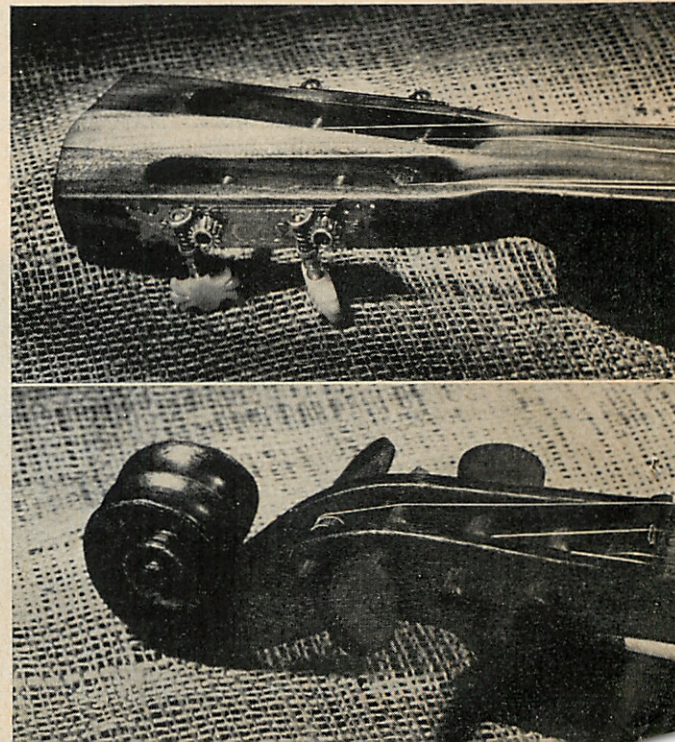

its own distinctive voice

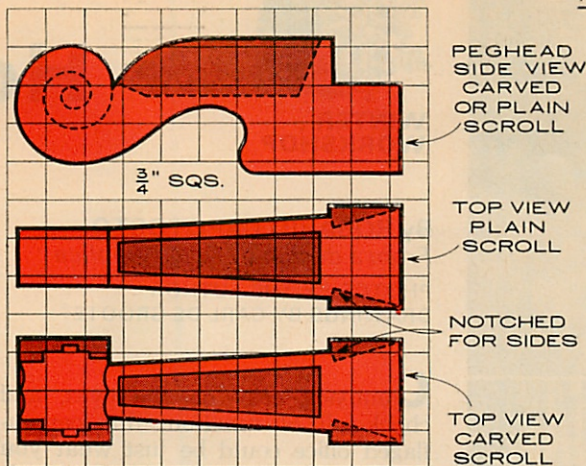
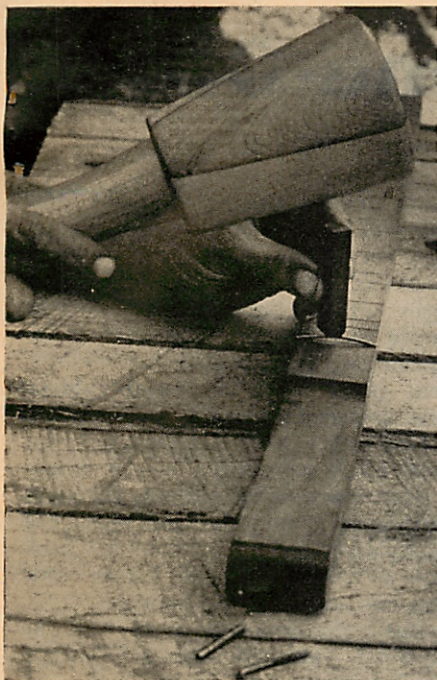

Tap frets into kerfs with mallet (a hardwood drift, here) and block. Curve each wire before installing, as shown.

FRETS CUT FROM 30" LENGTH OF BANJO FRET WIRE

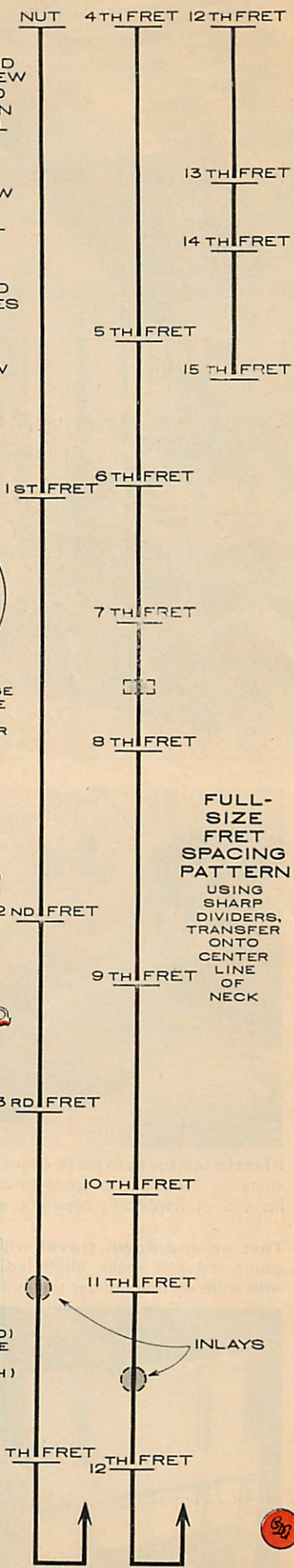

FULL-SIZE FRET SPACING PATTERN
 USING SHARP DIVIDERS, TRANSFER ONTO CENTER LINE OF NECK

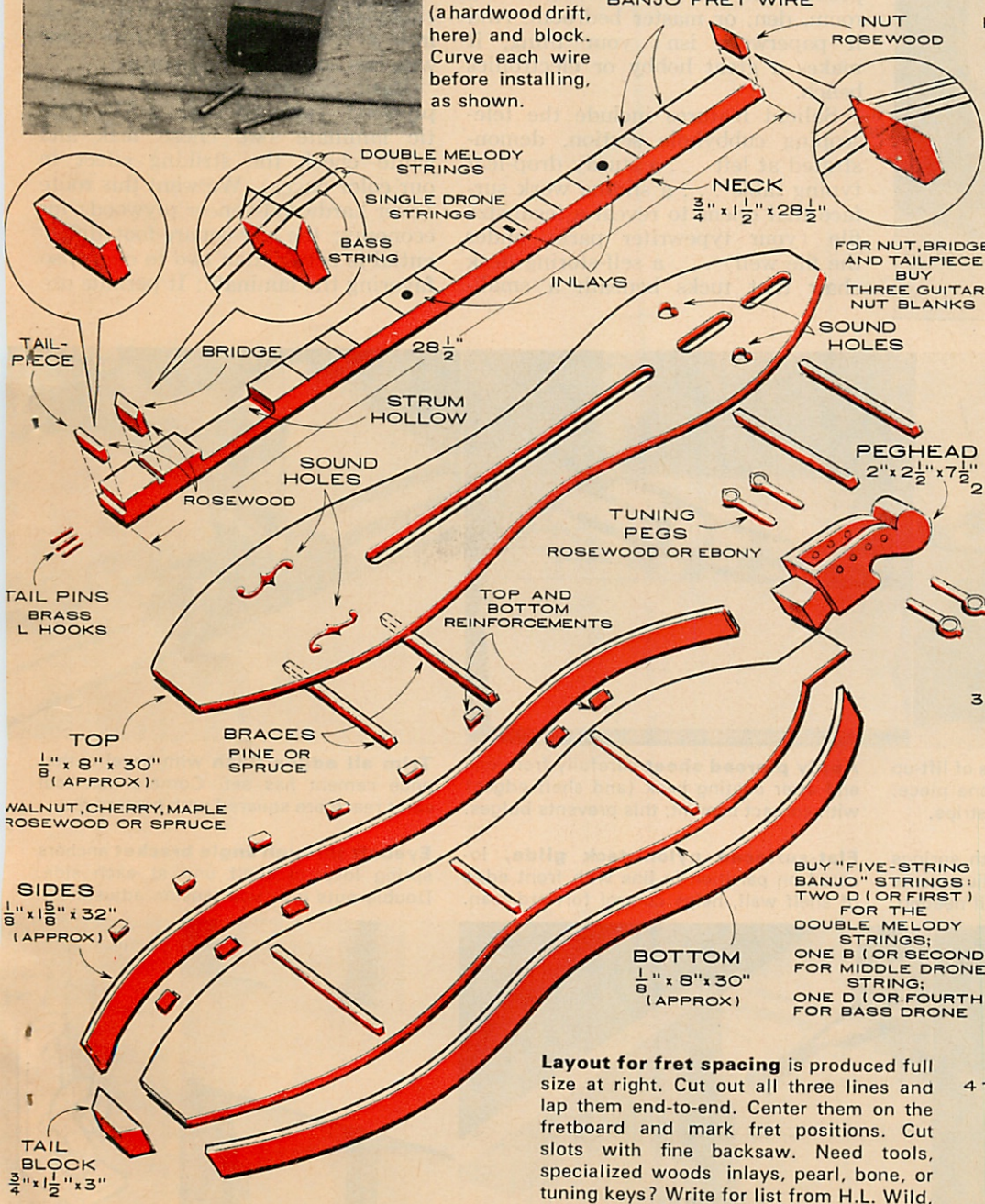

BUY "FIVE-STRING BANJO" STRINGS: TWO D (OR FIRST) FOR THE DOUBLE MELODY STRINGS; ONE B (OR SECOND) FOR MIDDLE DRONE STRING; ONE D (OR FOURTH) FOR BASS DRONE

Layout for fret spacing is produced full size at right. Cut out all three lines and lap them end-to-end. Center them on the fretboard and mark fret positions. Cut slots with fine backsaw. Need tools, specialized woods inlays, pearl, bone, or tuning keys? Write for list from H.L. Wild, 510 E. 11th St., N.Y., N.Y. 10009.



Wordless Workshop

By ROY DOTY

Idea by JEAN ROBERT HACHE

\$25 to Mr. Hache, Dalhousie, N.B., Canada. Send your idea to Wordless, Popular Science, 380 Madison Ave., N.Y., N.Y. 10017. Only purchased ideas can be acknowledged.

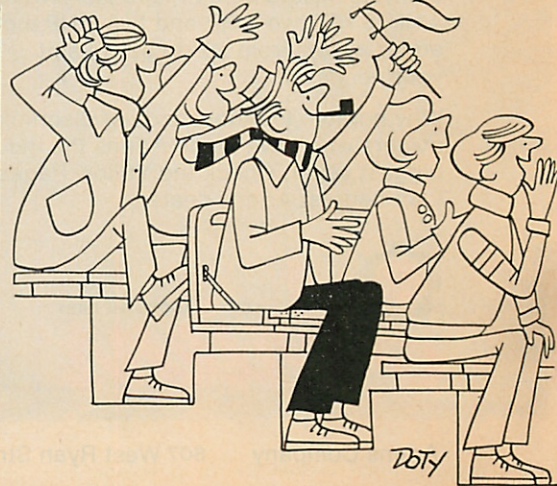
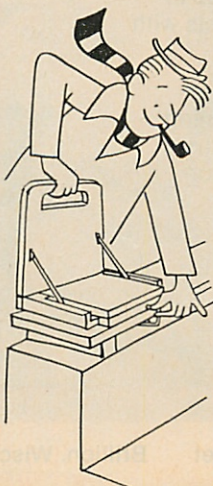
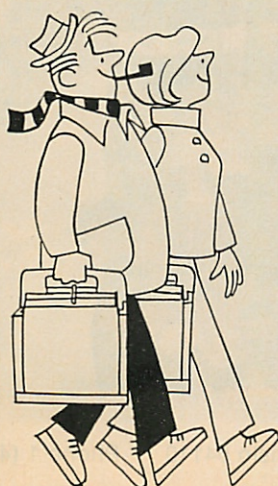
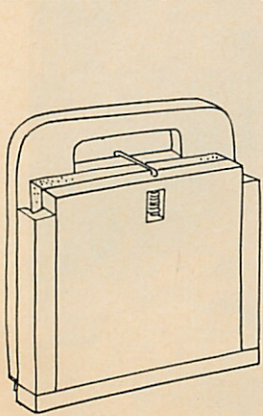
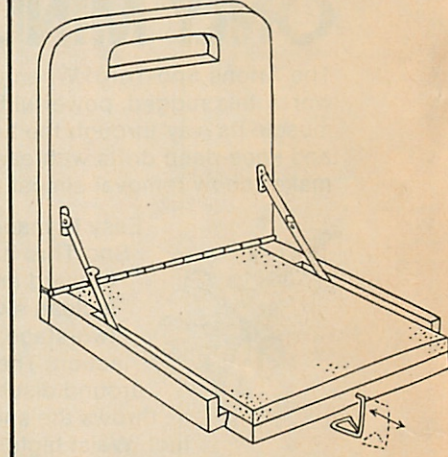
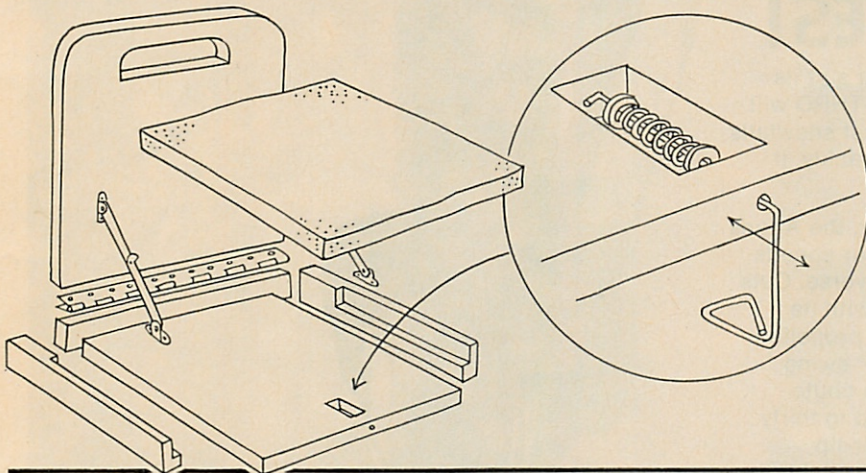
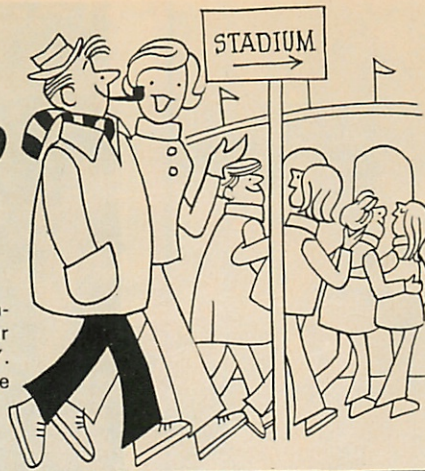

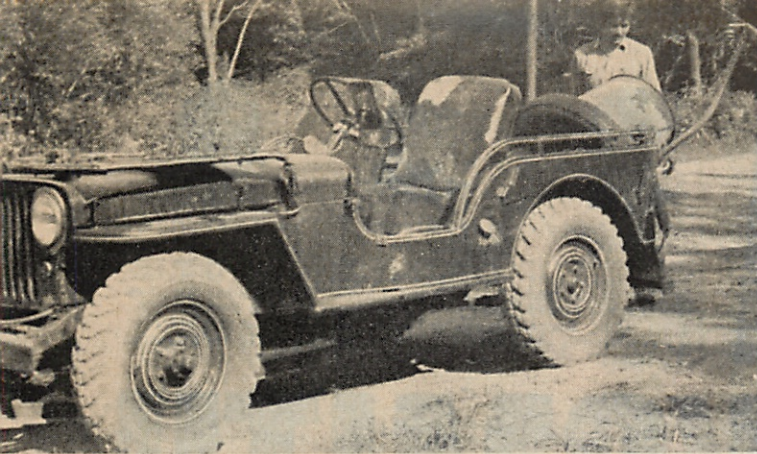

Top surface of pulley must be level with hole in supporting brackets where drum carrier is attached. Distance from top of pulley to centerline of horizontal coupling must equal the tire's radius; mixing drum must rotate as it is tilted up and down.

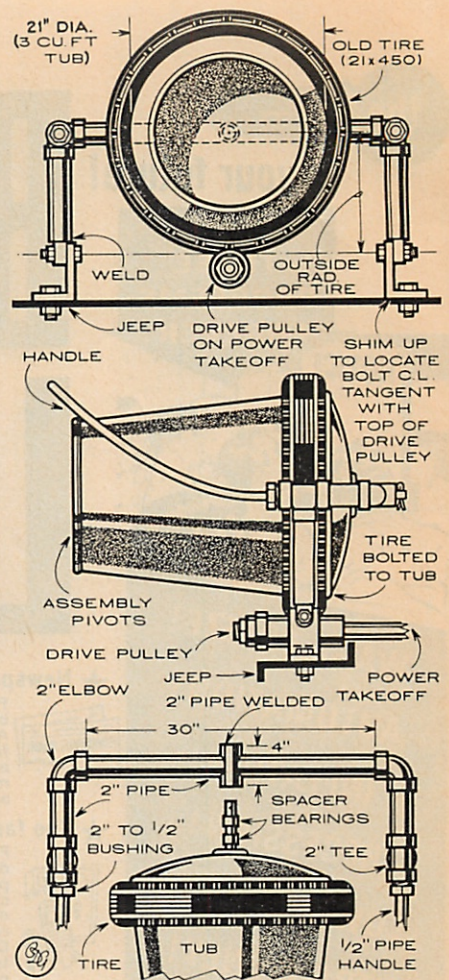

Your Jeep Can Mix Cement, Too

If you've got a jeep with power take-off and have small concrete jobs to do, this inexpensive conversion might really help out. Bolt an old tire around a standard mixing drum and attach a drive pulley of about five-in. diameter to the jeep's power takeoff; this turns the drum through contact with the tire. The U-shaped handle for tilting the drum up and down is bent upward to allow clearance for loading and unloading—*M. J. Alexander*

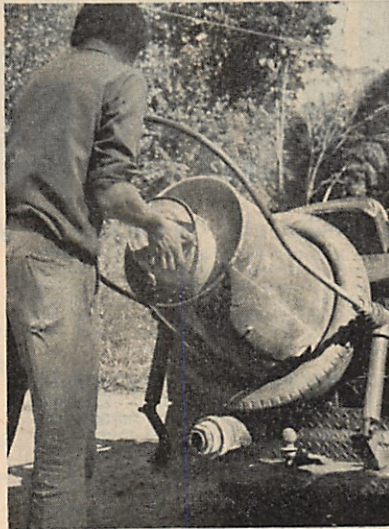

You Can Make a STEAM ENGINE From Stock Shapes—No Castings Needed!

RADIAL
Plan 5583 \$3.50

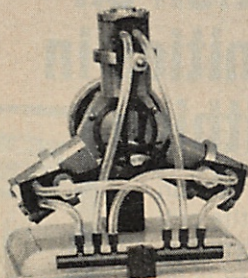

No small-shop project offers more satisfaction than the model steam engine. Here are four proven designs you can make without castings. All parts, drawn full scale, can be made from stock forms like bar, tube, and sheet.

For a starter, try Plan 5585, a simple single-action engine based on the fairly modern (as steam engines go) piston valve.

VERTICAL
Plan 5584 \$5

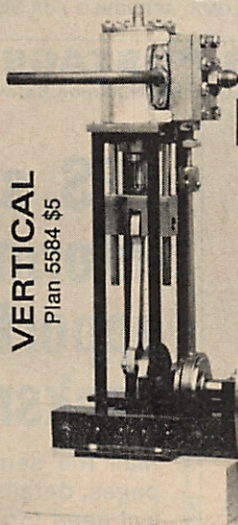

The compact, powerful radial engine (5583) runs in either direction, has no "dead center" position. Intended for compressed air or low pressure steam.

The larger vertical engine (Plan 5584) is challenging enough to satisfy even the experienced builder. Its 1" bore and 1 1/4" stroke in a double acting cylinder make it a powerful performer.

PISTON VALVE
Plan 5585
\$3.50

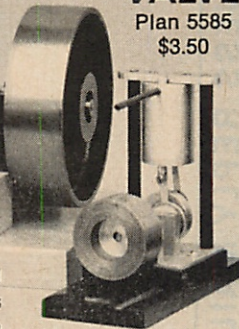

Two double-acting cylinders in the marine engine (Plan 5586) operate on cranks 90° to each other. Thus it starts dependably—ideal for radio-controlled boats. Recommended for experienced

MARINE
Plan 5586 \$6

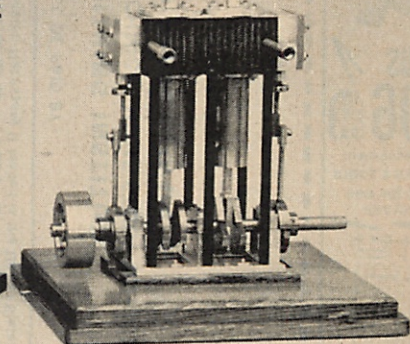

builders. **TO ORDER YOUR PLANS,** send your name and address (include zip code) with a check or money order (no cash). Ask for plans by name and number. Send to:

Popular Science Plans

380 Madison Ave., New York, N.Y. 10017 Dept. 42S



Incentive for learning

By STEVE ELLINGSON

Experts say that you can't teach a child by using force or by being harsh. The idea is to direct them into the learning process via some incentive to apply themselves. And that's why we designed both items pictured here. It takes the drudgery out of homework and encourages learning when a youngster can sit down to his very own desk. Of course, the toy storage cabinet encourages children to make neatness a habit because it will hold just about everything they own.

The top of the desk is hinged and opens to a compartment for books, paper, pencils and all sorts of study supplies. It's light and easy to move when cleaning time comes. The bottom of the toy cabinet is accessible

through two sliding panels. The area is ideal for footballs, baseball equipment and the like, as well as dolls or other large toys. You simply trace the pattern parts on plywood, saw out, assemble and paint.

To order the Child's Desk & Seat Pattern 74, send \$1.25. If you wish to place your child's name on the desk (as pictured), order our Letters and Numerals Pattern 66 for 75 cents. To order the full-size Toy Cabinet Pattern 466, send \$1.25 by cash, check or money order to:

Steve Ellingson
Register-Pajaronian
Pattern Dept.
P.O. Box 2383
Van Nuys, Cal. 91409

Wordless Workshop

By ROY DOTY

Idea by W. G. TAYLOR

\$25 to Mr. Taylor of Bracebridge, Ont. Send your idea to Wordless, Popular Science, 380 Madison Ave., New York, N.Y. 10017. Only purchased ideas can be acknowledged; none are returned.

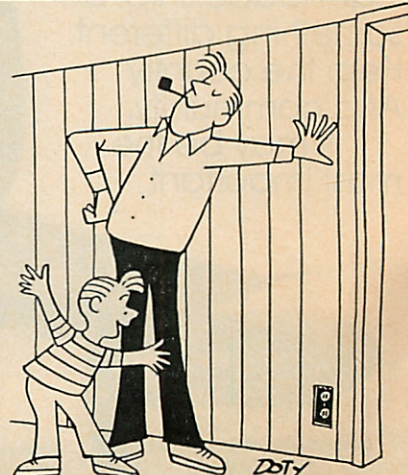
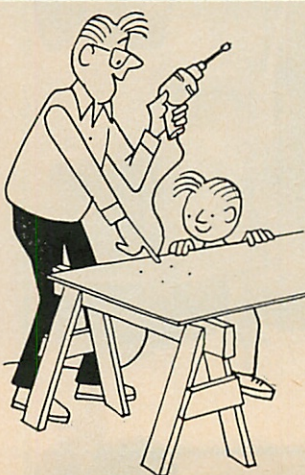
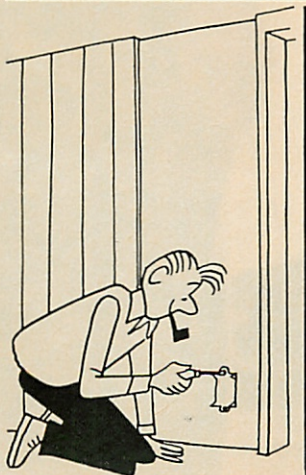
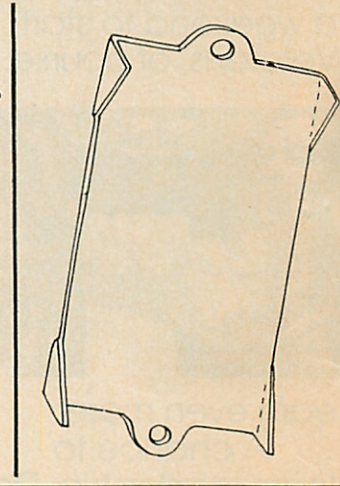
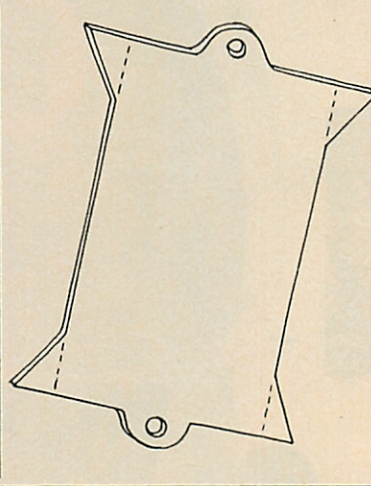
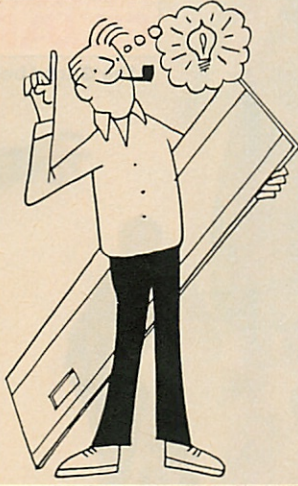
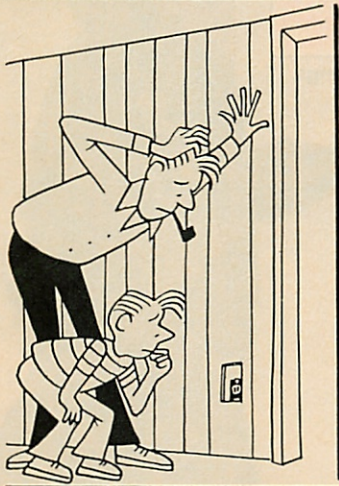
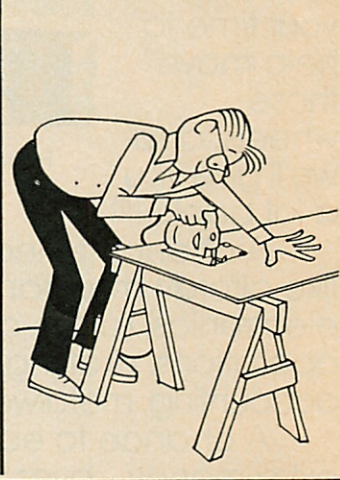
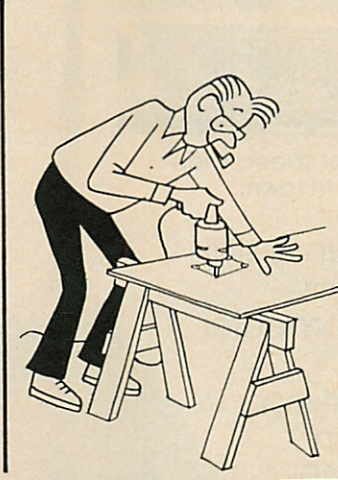
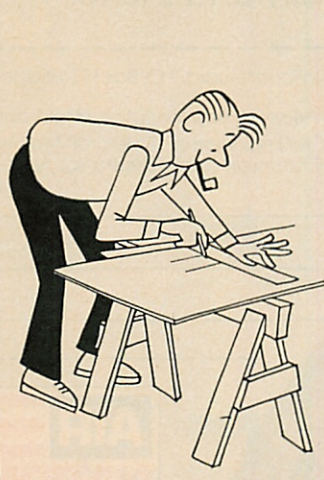
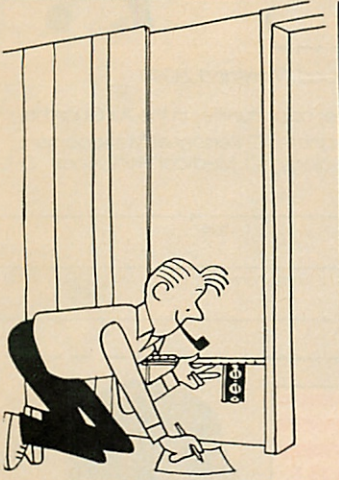
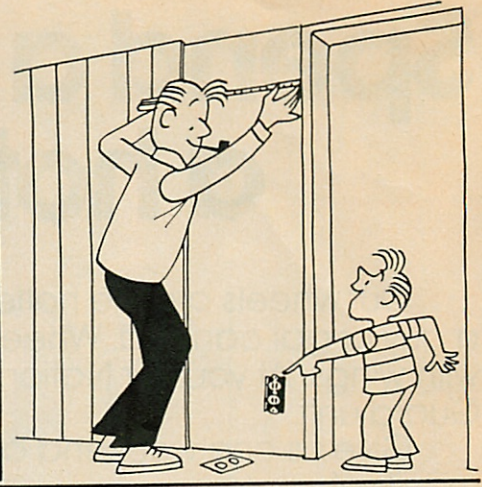
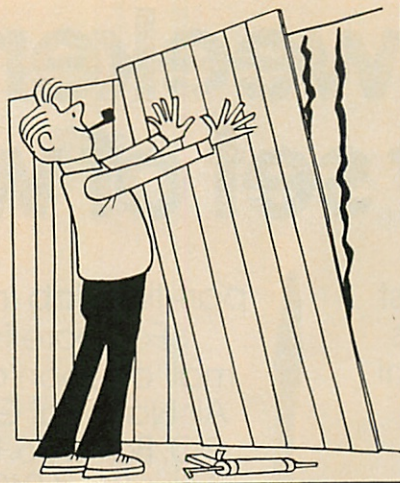

DOTY

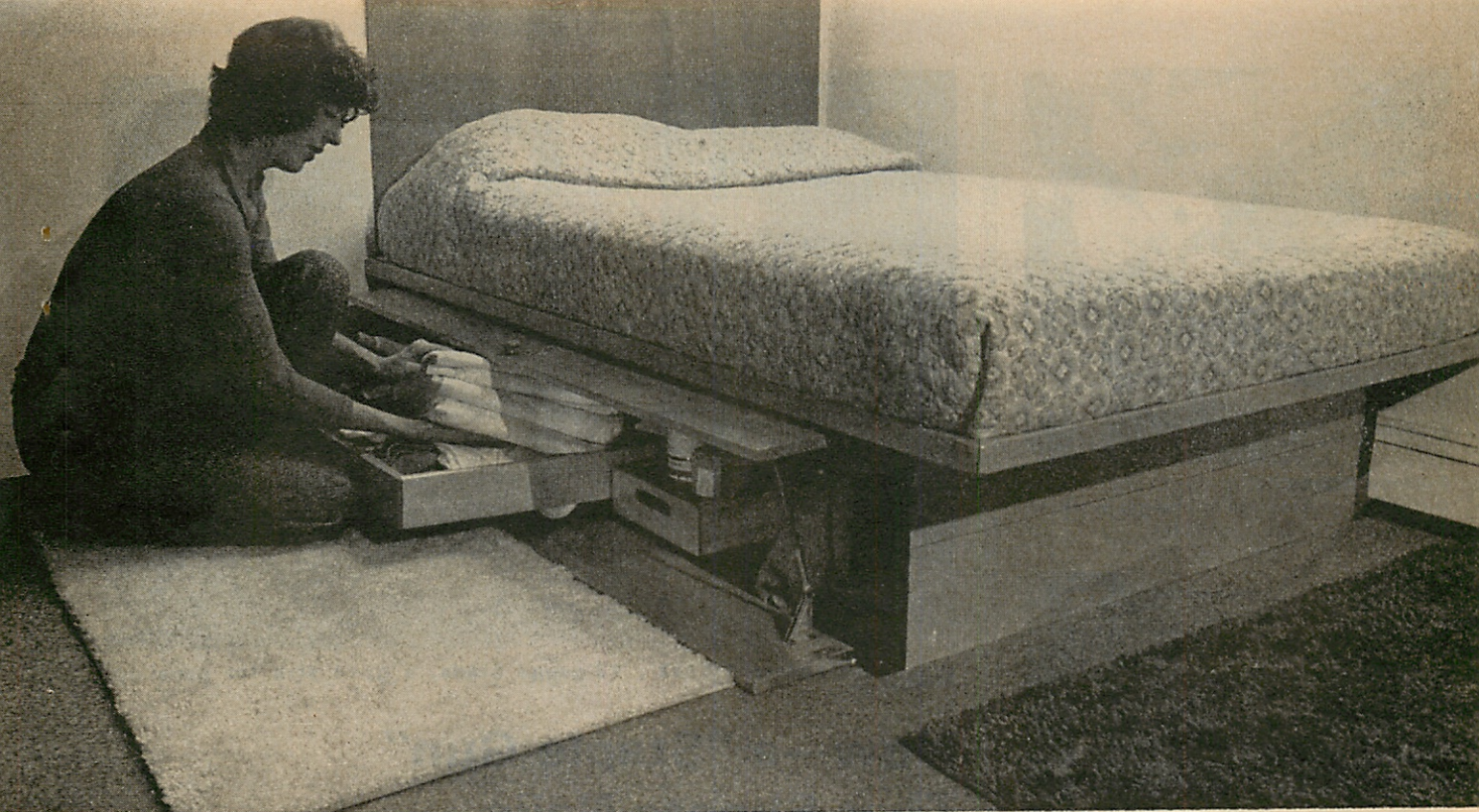

Roll-out storage carts are easier to make than drawers. They hide behind unique over-and-under door assembly.

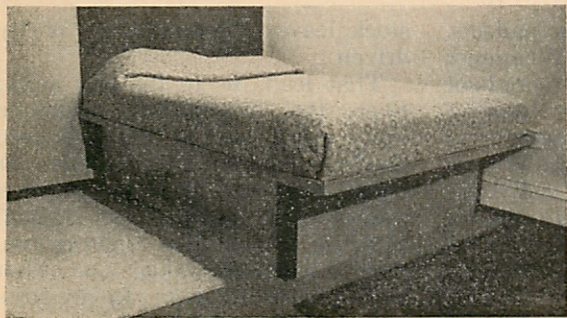

Sturdy Platform

Big roll-out carts hold mountains of bedding. One sheet of plywood makes a platform for a full-size mattress

Solid comfort above, plenty of storage space below—that's what you get from this sleep platform. Plus strength enough to handle a double water bed, if that's your bag.

Construction starts with the base. Rabbet the 4-by-4 for the corner posts while still in one piece. Cut the two door-side posts to accept the 2-by-4 stringer over the door opening. Assemble the ends first, using glue and clamps.

The long fixed side and the 2-by-4 stringer are added after the glue dries on the end assemblies. Use a pair of 15-foot web clamps in series around the whole bed. The lower door, shimmed at one end, prevents the base ends from twisting.

To fit the doors, route recesses for hinges where they fit doors and posts. Use cabinet hinges for flush overlay doors. I used Amerock's model 1242, designed for $\frac{3}{4}$ " doors.

Door linkage. Make this from a replacement door closer (I used the SK-95 Ideal Security). You need the lever, short pivot, and rod.

Saw through the cylinder to free the rod. To assemble the linkage, see the sketch detail. Locate the lever and cut the rod to length first; then locate the short pivot ("A" in the detail) with both doors closed.

Sleep platform. This is made from a plywood sheet, shortened and widened by means of the wedge technique shown on the cutting diagram. Reinforce the resulting diagonal seam with a glued-and-screwed doubler made of 2-by-4 stock or $\frac{3}{4}$ " plywood. Plywood for the platform should be B grade or better on the top to minimize mattress wear.

Edge the platform with 1-by-2 stock, rabbeted, glued, and clamped as shown in the plans. You'll need wider stock (or plywood) for the edging if you use a waterbed. Reinforce the corner joints with glue blocks or angle irons and screws.

There's no need to fasten the platform to the base; its weight holds it down. But a screw through the plywood into each corner post will add rigidity to the base.

Storage carts. These roll on small wheels. Size isn't critical, but they should be about 4" diameter to roll easily over the lower door. I got mine from A. Liss & Co., 3860 13th St., LIC, N.Y. 11102. You can order a set of eight for \$9.75.

As shown in the plans, the carts have pine frames and plywood bottoms. Axles for the wheels fit into holes drilled through the cart sides and into the edges of the bottom. Front wheels are set back so the cart can come partly out before it has to rise over the lower door.

Finish with thorough sanding and several coats of varnish. Don't sand the platform top; a single coat of varnish here will bring out the right texture for a nonskid surface that will keep the mattress in place.

Variations: Doors look too fragile for the kids' room? Eliminate them and size the cart fronts to fill the opening. They'll look like drawers. King or queen size? The platform will take more than a sheet of plywood, and need a center support. **E**

Storage Cabinets Made Easy

Storage cabinets are handy to have, but tricky to make—especially the drawer slides.

When I needed a small cabinet to store negatives, I used a design that simplifies slide construction. The drawer bottoms are made of $\frac{1}{8}$ " hardboard $\frac{1}{2}$ " wider than the drawers. This gives the bottom $\frac{1}{4}$ " tongues along the sides that fit into $\frac{1}{4}$ "-by- $\frac{1}{4}$ " grooves cut in the sides of the cabinet.

The drawing shows construction details. Choose dimensions to suit your needs. This design is for a small cabinet, just a little over a foot in height, but you can expand to a much larger size by beefing up the drawers. Switch to $\frac{1}{4}$ " hardboard for the bottoms, and $\frac{5}{8}$ " plywood for front, back, and sides.

When the cabinet is complete, hand-sand the sharp corners off the drawer slides. Then rub them lightly with paraffin.—*R. S. Hedin*

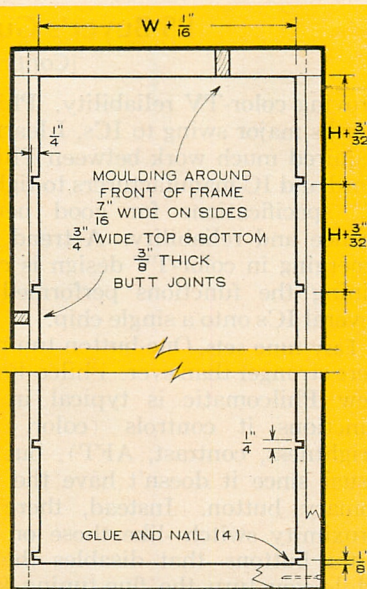

FRAME $\frac{3}{8}$ " THICK STOCK
"L" INCHES DEEP



Small cabinet is open at rear; larger size will need a back to reinforce frame.

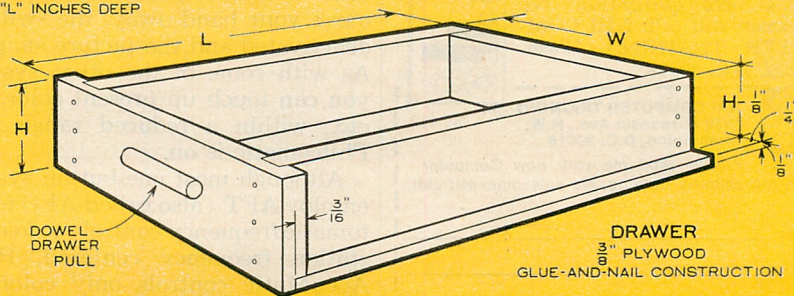

DRAWER
 $\frac{3}{8}$ " PLYWOOD
GLUE-AND-NAIL CONSTRUCTION

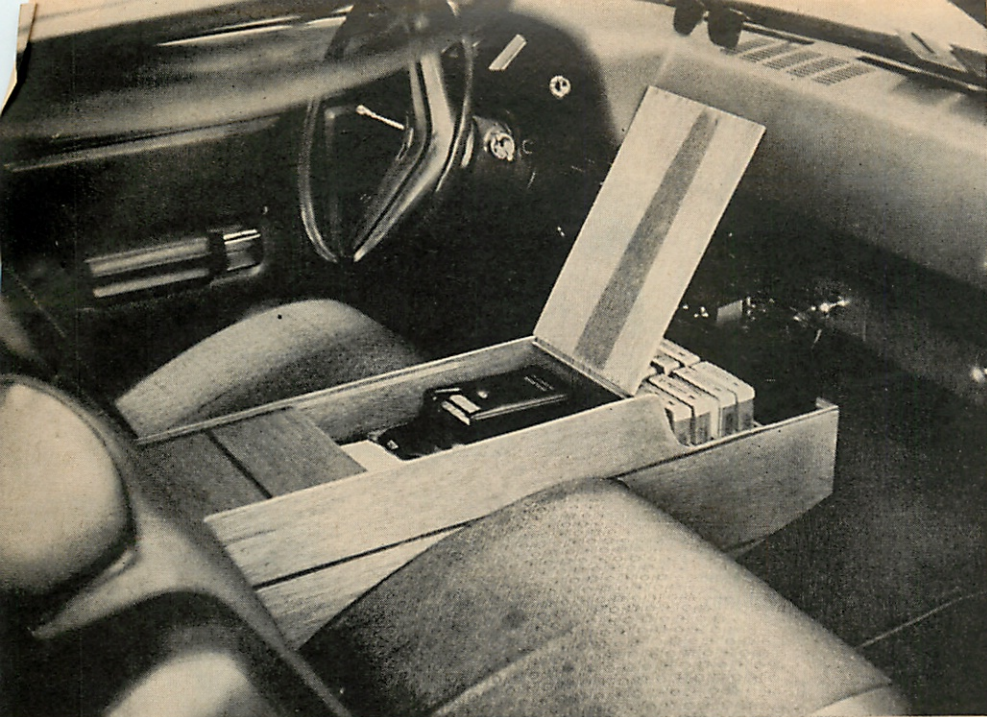

ONE-WEEKEND PROJECT
 \$200
 DESIGN
 AWARD
 COMPETITION

FIFTH MONTHLY WINNER:

Charles W. Blaker
 of Chatham, Va.

Front-seat clutter comes to an end with this neat, efficient storage console.

Car-Seat Console

Prefinished paneling eliminates the need for time-consuming stain-and-varnishing steps. Just cut the parts to size and shape, finish up by gluing and brad-
 ing them together.

You're stuck with a stodgy bench-seat family car? Worse yet, the seat is cluttered up with credit-card receipts, sunglasses, eight-track tapes? The glove compartment's stuffed with pencils, sunglasses and maps? Then clean up your act with this car-seat storage console.

This month's contest winner designed it to fit a 1970 Mercury Montego, but a little alteration of the bottom profile will fit it to the seat and transmission hump of any full-seat car. Internal parts remain the same.

You can make it from a few scraps of prefinished paneling and some one-by-ten pine. Start by making cardboard templates of the side panels and the two pine cross members that rest on the transmission hump. Make the cross members first, then use them to develop the profile of the side panel. When you're satisfied with the fit of the templates, duplicate them in wood—one-inch pine for the cross members, prefinished paneling for the side panels.

Next, cut the dadoes for the sliding cup cover and for the partitions and shelves. Cut out the remaining internal parts and assemble with glue and brads. A pair of small brass butt hinges attach the cover. Finish? If you've used prefinished paneling, none is required.

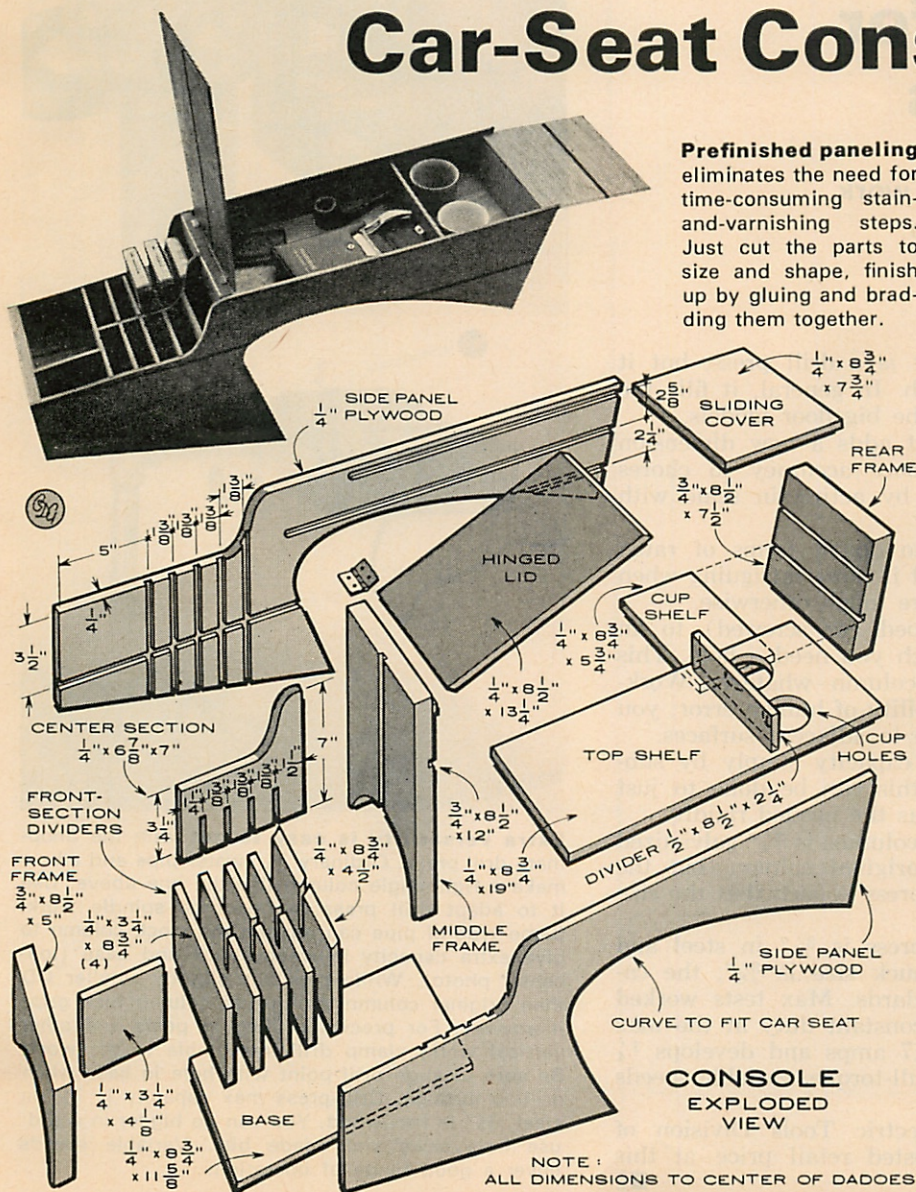

Note: Though the Weekend Project competitions closed in December, we'll continue to present the monthly winners through April.—The Editors



GLASS ETCHING

A simple sandblaster
you make yourself is the
key to expert etchings

By A. LEE SHAWCROSS

Have you always felt that decorative glassware work was difficult, time-consuming, and best left to the experts? It isn't. You can etch a monogram on a brandy snifter in less than an hour from start to finish. And making the device to do the etching takes only an evening or two.

The object is to rough up the surface of the glass in selected spots.

Famous cover
becomes an etching



As a dramatic demonstration of the quality detailing that is possible with his simple rig, the author reproduced, full size, our centennial-issue cover—complete down to the last gear tooth—and sent it to us framed with a mirror backing (a striking but unphotographable effect). When we asked Shawcross how he did it, he wrote:

"Very carefully! Made several Xerox copies of the cover to reduce it to tones of gray, then took a sharp felt-tip pen to ink out what should go black (clear) and what white (etched).

"This reduction was taped down as my mask guide. The cutting and stripping was tedious: worst was the small lettering, with artist Ray Pioch's signature a special challenge. But after 10 hours of preparation, 10 minutes at the etcher finished the job."

This can be done by acid etching, but that is messy and dangerous. Grinding is the method used by the pros, but that's what you have to be to do it successfully. Our approach is much simpler: "Sandblast" the surface through a simple paper mask.

The attachment to an air compressor (detailed next page) shoots particles of abrasive grit against unprotected areas of the glass. Each one digs out a tiny particle of the smooth surface, leaving thousands of tiny prism-like surfaces which scatter light in every direction.

The etcher. The sketch at right gives the details for making this attachment. The foam can be found at any plastics shop or any outfit that supplies packaging material. Use the 2" thickness specified or you may not have enough "hump" around the hole to press into for a seal.

As a control valve, I used a simple globe valve from my plumbing box and it works fine—I hold the piece down with one hand and operate the valve with the other. As an air valve, it leaks slightly, but the small stream of air constantly escaping from the nozzle keeps the grit from falling into the hose between shots. I have to be sure to disconnect the line between uses, though—at the quick-disconnect fitting.

If you decide to use a foot valve (available from Linemaster Switch Corp., Woodstock, Conn. 06281), put a loop in the line so grit can't fall back into it; otherwise the valve will jam up fast. And again, provide a leakage path (a small valve or orifice in parallel would do) to keep the line clear while in use.

As for grit, ordinary sand will etch, but silicon carbide is faster and better. Get it from an industrial-abrasives supplier or, as spark-plug-cleaning grit, from an automotive-supply house. Finer grit gives a smoother matte surface, but for all-purpose use a 60-mesh grit is fine.

When mounting the device, locate it as you would a spray-painting station: Keep it away from tools and equipment, since the grit that inevitably escapes will wreak havoc with machinery bearings, joints, etc.

With your attachment hooked up and loaded with grit, you are ready—with goggles on—for your first project. The numbered photos show how a brandy glass was done and this, essentially, is the process for any job.

A word about pressures. An at-the-nozzle pressure of 20 psi is ade-

quate to etch the glass, though somewhat slowly. The higher the pressure, the faster the job. Most of my work is done around 60 psi (40-80 psi range). Anything over 80-100 psi is probably too much and could pose a safety problem.

If you need help making designs, turn to drawings and photographs in magazines. Lettering systems (such as Artype, Prestype, and Letraset found in art stores) are an easy route to neat, stylish letters and numbers. In choosing designs, remember straight lines are easier to handle than curves.

Another point to remember is that you have only two "colors" to work with—clear and frosted. Lettering and pen-and-ink work are the easiest to use. Continuous tone work (photos, paintings, etc.) run the gamut from relatively easy to translate into two tones to nearly impossible for anyone but an artist to handle.

When you find a pattern you like that's the right size for the job, either copy it in a copier or make a tracing of it on onion skin. But keep the original intact as you'll inevitably want more. This copy then becomes the guide for the mask.

Making the cut. That's the secret of the whole process—the knife must be kept sharp and the cutting careful. Pieces of razor blade or an X-Acto knife are as good as anything I've found. But whatever knife you use should be of the best possible steel or the cutting point will dull quickly. Nothing will frustrate your attempt to do a good job like a dull knife. If the blade feels as though it's starting to drag—even a little—break it back to a new point or get another blade and use the spent one for some other job.

As you cut, you'll find you have to go slightly beyond the intersection or corner of another cut to clearly sever the tape. Be careful not to overcut too much, however, as the blade can scratch the glass (some glass is very "soft") and would leave unsightly marks projecting into otherwise clear areas.

Most pieces of tape to be removed can be lifted directly with tweezers. Thin lines—where two cuts are very close together and the tape on either side is to remain—sometimes call for a different technique. After making the cuts, position the tip of the blade or a pointed object at one end of the strip and try pushing it out of the

Continued

Is Easier Than You Think

N° 10 F.H. WOOD SCREWS
6 - 1" LONG
6 - 1 1/2" LONG

BATTEN STRIPS
2" x 1/4"
(USE 1/4" PLYWOOD)
MATCH DRILL AT
ASSEMBLY

2" (MIN.) THICK
POLYURETHANE
FOAM
(2 LB/FT³)

HOPPER
SECTION
(SEE DETAIL)

NOZZLE
(SEE
DETAIL)

TABLE
PLYWOOD

3" LAG SCREW
(2 REQ'D)

2 x 2
SUPPORT
(2 REQ'D)

1/4" AIR
HOSE

TO COMPRESSOR

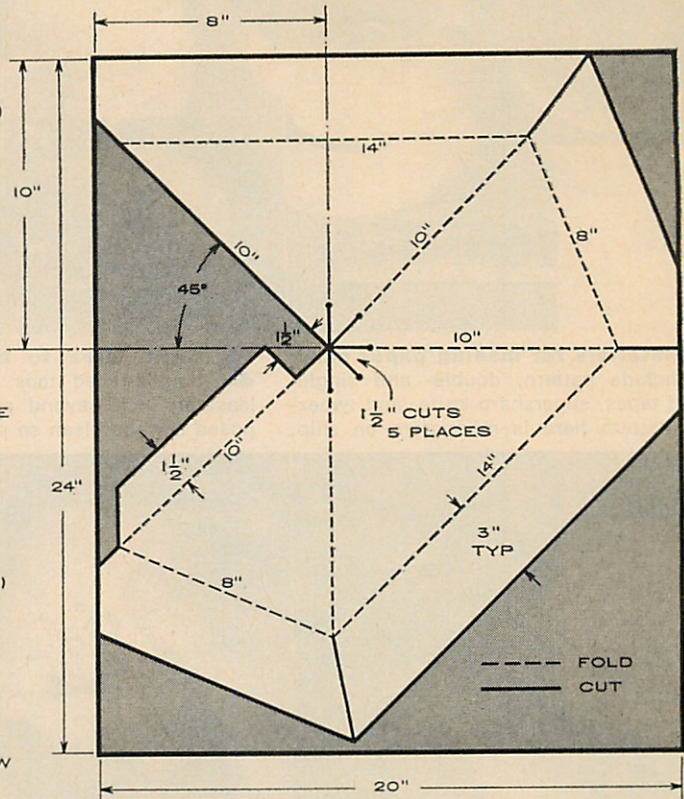

HOPPER LAYOUT

USE .020" FLASHING AL.
STD. WIDTH - 20" MAX.

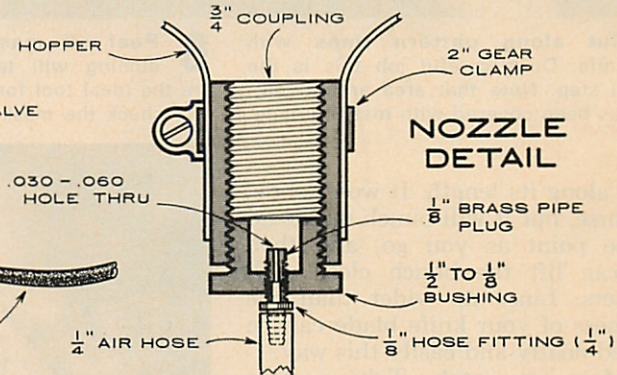

NOZZLE
DETAIL

Etching attachment is easy to make. Aluminum hopper is bent and riveted to shape, all seams silicone-caulked to prevent grit leakage. Hose clamp secures nozzle to hopper.

Two-inch-thick urethane foam forms etcher's work surface. Clamp the foam down over hopper, screw in place with battens. Be sure to pull the foam down good and tight all around.

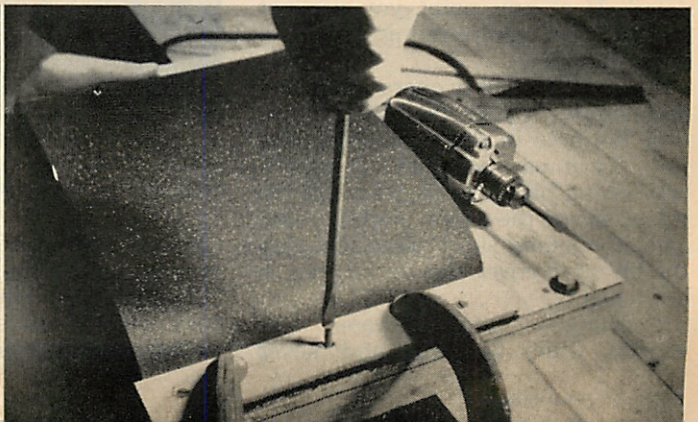
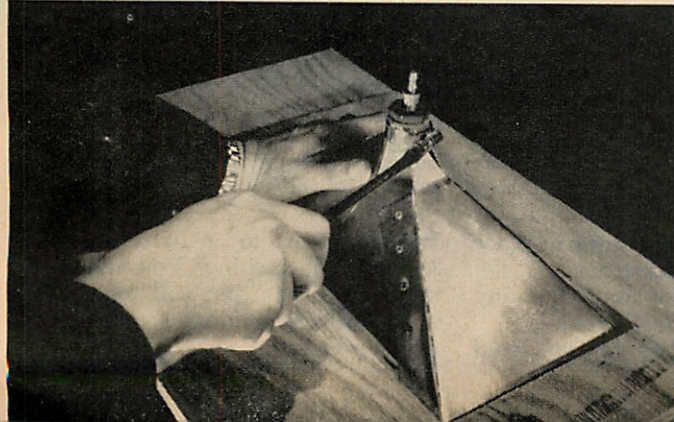

How to etch your own family heirloom in seven easy steps

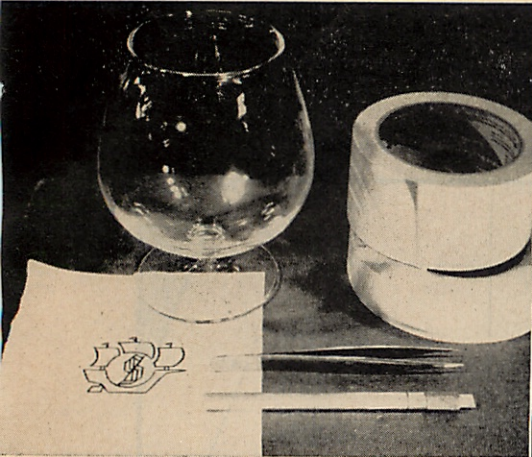

1 Materials for making paper mask include pattern, double- and single-faced tapes, supersharp knife, and tweezers. Pattern here is monogram on ship.

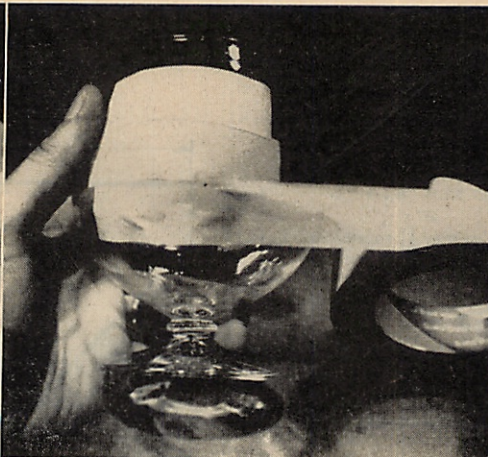

2 Cover area to be etched with double-faced tape. Extend tape at least an inch beyond pattern. Keep exposed surface clean so pattern will stick.



3 Position the pattern where you want it and work it down firmly onto the tape surface. On curved surfaces, distribute any wrinkles evenly.

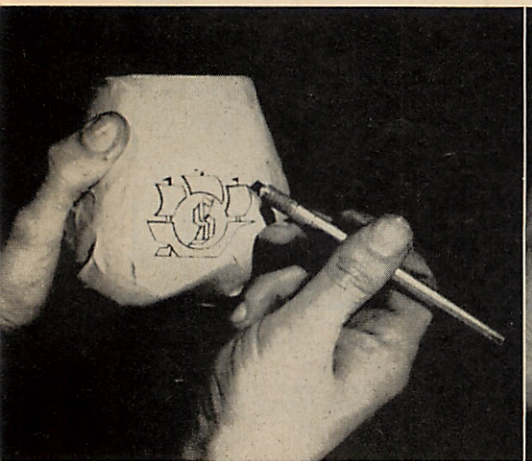

4 Cut along pattern lines with knife. Do a careful job—this is the critical step. Note that area around pattern has been covered with masking tape.

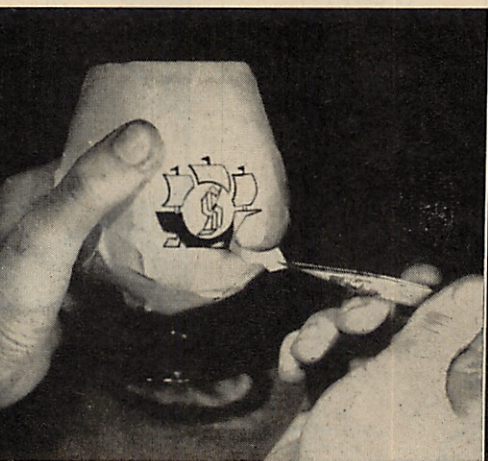

5 Peel off mask and tape where etching will take place. Tweezers are the ideal tool for this job. After peeling, check the mask for flaws. Fix them.

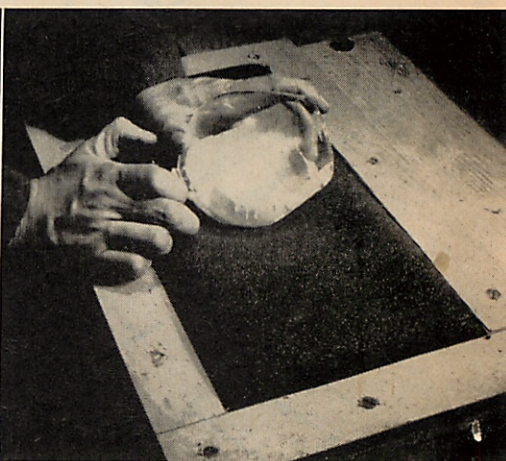

6 To start etching, press exposed area firmly but gently down over the hole in foam work surface. Use overlapping two-second blasts on design.

mask along its length. It won't slide, of course, but it will bunch up ahead of the point as you go, and then you can lift the bunch clear with tweezers. Lines no wider than the thickness of your knife blade can be cleared neatly and easily this way.

Before you etch. Take a close look at your mask to be sure it's right. After the grit hits it, it's too late; the resultant pattern is amazingly faithful to the mask in every detail. If at any point you are not sure of what you're doing, try it on scrap glass first.

The actual etching operation is fast and simple. Press the work down over the hole in the foam work surface. Turn on the valve to give a two-second blast of grit. Turn off the valve, move the work slightly, and give it another short blast. Overlap the blasts to cover the entire area to be etched.

Cautionary notes: Always wear goggles while working, and never

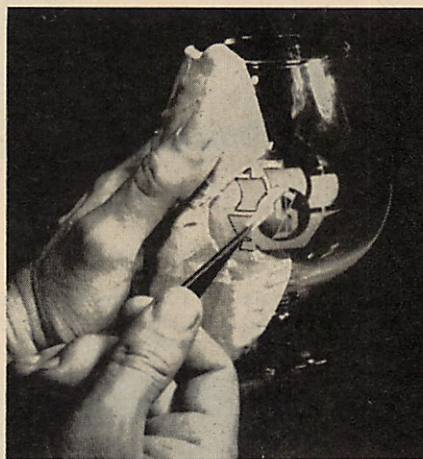

7 Remove the remaining mask and tape, clean the glass, and check your results. This method of etching allows for very fine detail with careful work.

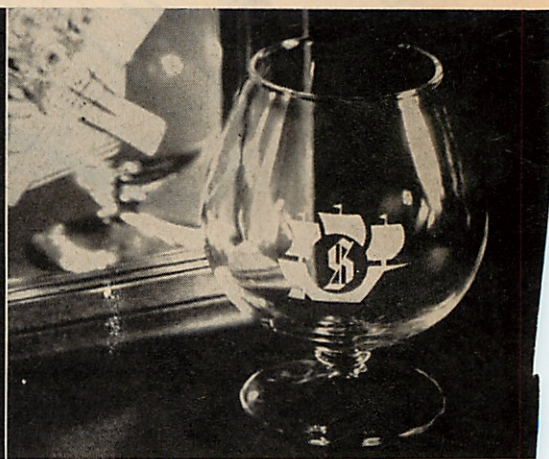

Finished snifter becomes a work of art. Practice a few designs on scraps of ordinary window glass before you attempt to etch expensive glassware.

open the valve without work in place over the hole in the foam.

Inspect the mask and fix any flaws before you start etching.

Check your work as you go. Hold

the glass up to a light and look through the etching. You can easily spot any areas that call for another shot. But the etching goes quickly—don't overdo it. **PS**

ONE-WEEKEND PROJECT
 \$200
 AWARD
 EACH
 MONTH
 COMPETITION

THIRD MONTHLY WINNER:

Robert J. Oswald
 of Tempe, Ariz.

Are you short on display space for your favorite books and magazines? Do you like the touch of life that plants can add to a room? Then build this end table. Up front is a shelf for magazines. In back, a built-in planter.

Fill the planter box directly with soil, or set potted plants in the box and cover with sphagnum moss. In either case, a waterproof planter lining is a good idea. Solder a galvanized steel liner if you like, or take the easy way out and use epoxy paint for waterproofing.

Choice of wood is yours. The table above was made of solid walnut for a little over \$20. Pine and oak (stair tread is a good source of clear oak) do nicely, too. If you want a modern, glossy plastic look, use plywood for everything but the legs and trim. Finish with enamel.

All parts of the table go together with clamps and white glue. One exception: The legs fasten on with flathead screws to allow for easy removal and transportation.

Finishing. Walnut and oak usually look best with a natural oil finish. Watco Danish Oil is a good choice. If the walnut has streaks of light sapwood, use a walnut stain before brushing on the oil. This will give the wood a uniform tone.

Pine is best sanded carefully, then stained and varnished. And the best stains for pine are those that simulate the look of aging.

Gloss-enamel finish requires careful sanding. Apply at least three base coats of enamel. Let each coat dry overnight, and sand between coats with 220 paper on a block. Before the final coat, wet-sand with 320 waterproof paper.—*The Editors*



Table is most at home near window where plants get plenty of light.

End-Table Planter with Magazine Shelf

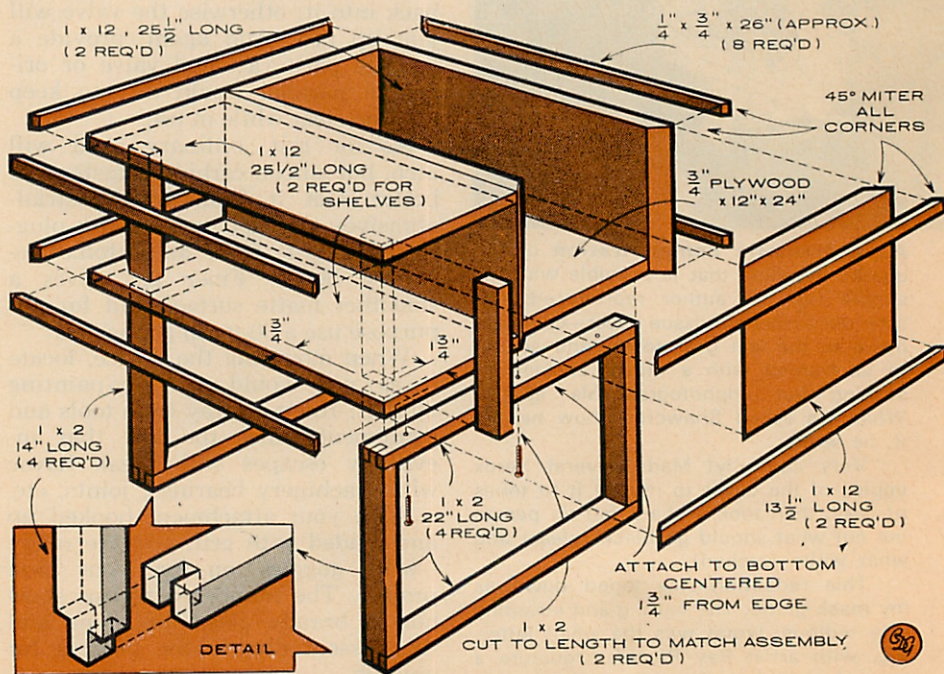

Wordless Workshop

By ROY DOTY

Idea by D. S. BURCH

\$25 to Mr. Burch of Ft. Worth, Tex. Send your idea to Wordless, Popular Science, 380 Madison Ave., New York, N.Y. 10017. Only purchased ideas can be acknowledged; none are returned.

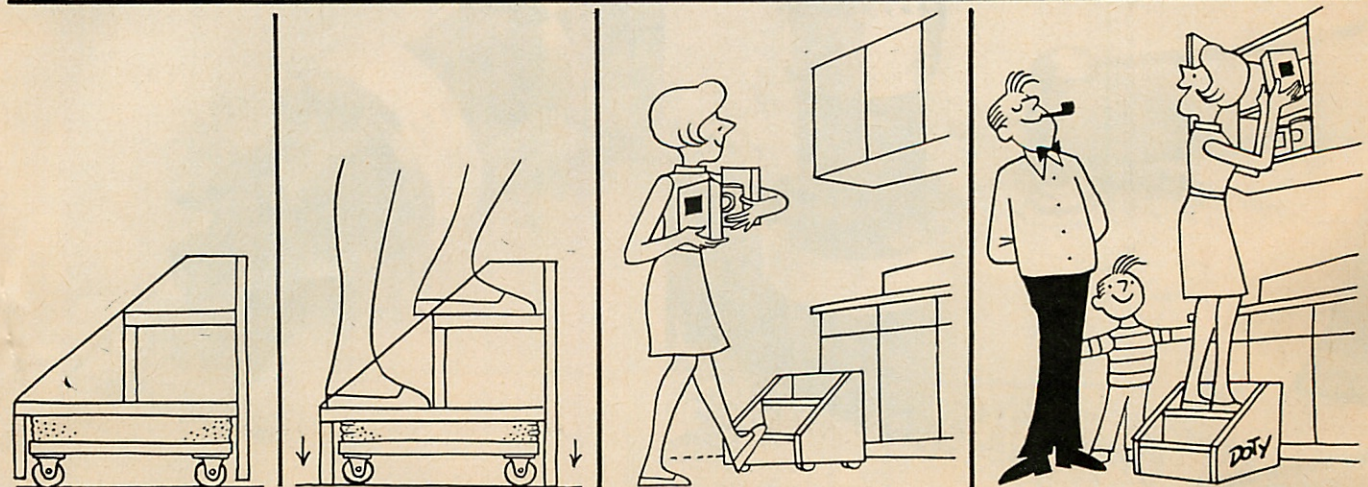
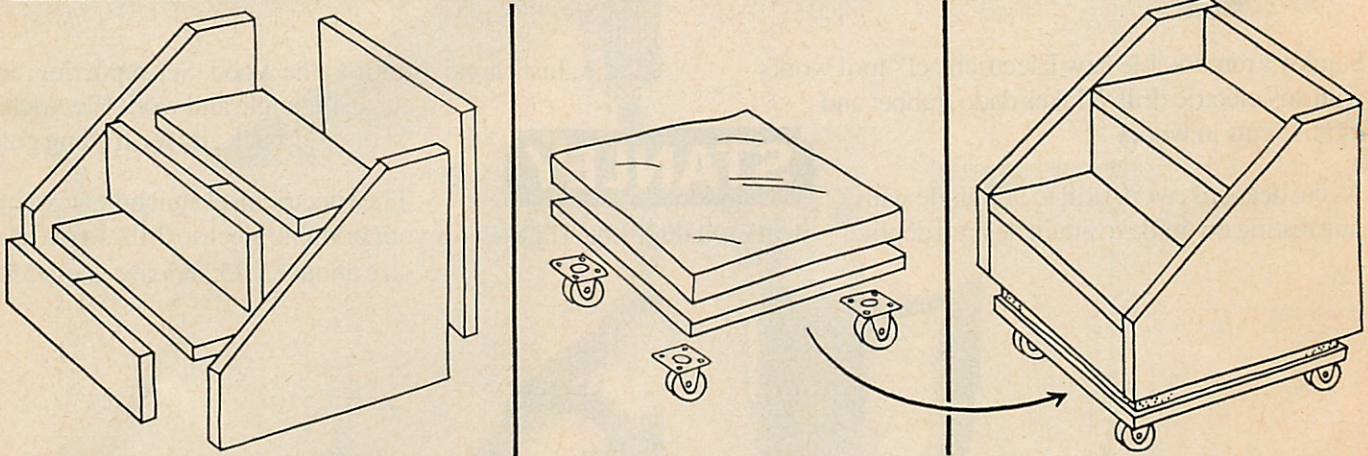
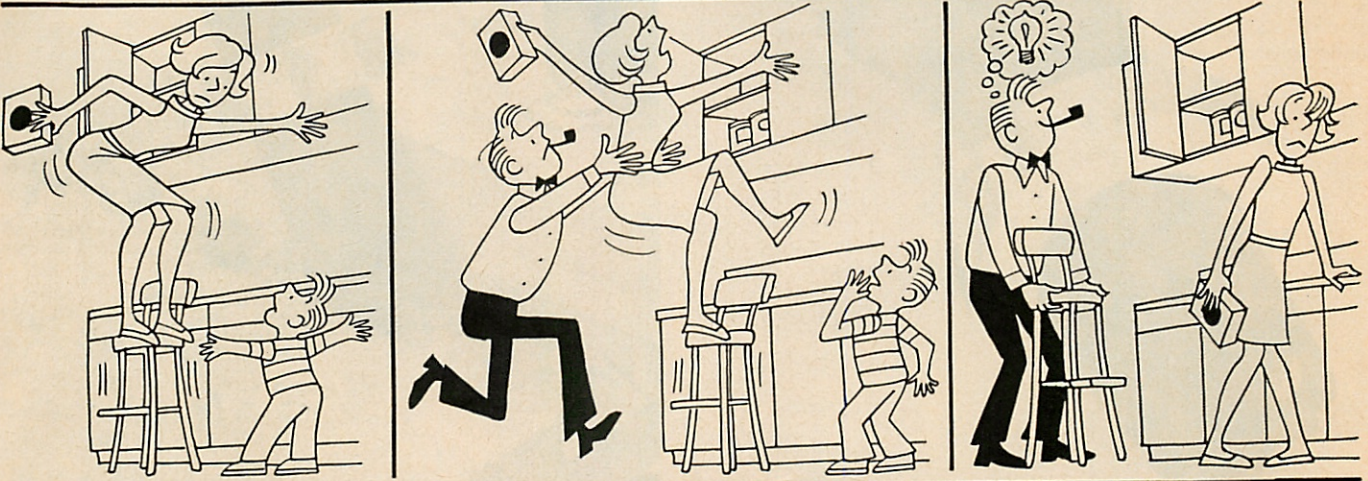
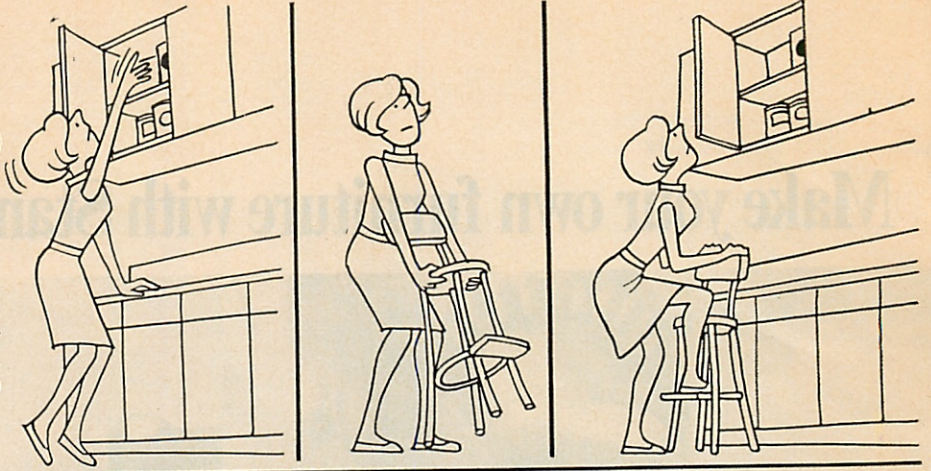

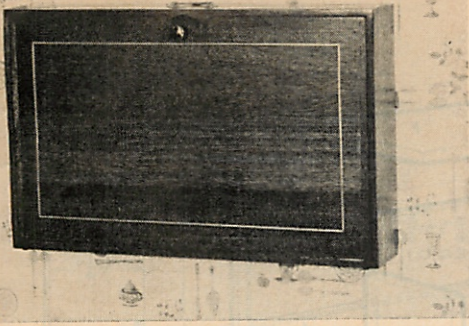

Brass-trimmed hardwood makes desk at home on any wall. Here, it's a kitchen record center. Closed, it projects only six inches. Abcrite bins reveal contents.

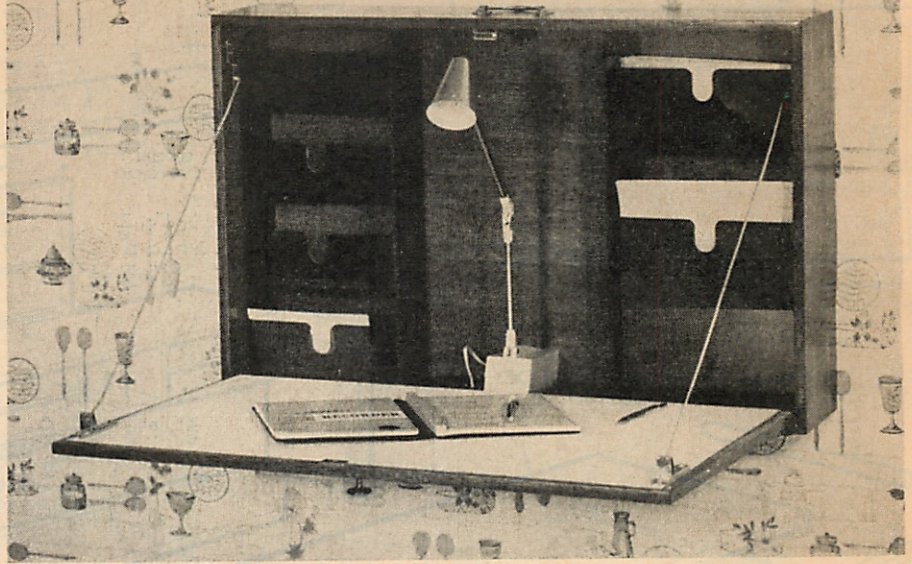

WINTER WORKSHOP

Portable Wall Desk

By **RICHARD C. SICKLER**
DESIGN AND PHOTOS BY AUTHOR
DRAWINGS BY CARL DE GROOTE

Here's a desk for the family to fight over. It goes wherever it's wanted (taking its lamp along) and hangs from a pair of picture hooks on any wall. Your wife will use it in the kitchen for menu planning; you'll move it to the den to go over household accounts while keeping an eye on the TV ballgame; a teenager may

spirit it away to her room for letter writing. Come spring, when you all shift these tasks to the patio or porch, the desk moves outside.

Those see-through cubbyholes are made of a new plastic sheet—Du Pont's Abcrite. Actually, it's acrylic—like Plexiglas or Lucite, but it's coated with an abrasion-resistant fluoropolymer. I chose it because a transparent material makes sense here, allowing a visual check of all contents before you pick up and go. And the cubbyholes need front closure to prevent spillage in transit.

Unsurfaced plastic might scratch—especially with those drop-leaf support cables coiled against it for travel. The coating prevents use of a standard solvent adhesive for joints; however, I experimented with several alternates, and settled on Dow's clear silicone adhesive.

Construction. Begin with the case. I used $\frac{1}{2}$ " Philippine mahogany; back and lid panels are glued up from three butt-joined boards. You could, of course, substitute $\frac{1}{2}$ " cabinet plywood to avoid this, using

[Continued on page 132]

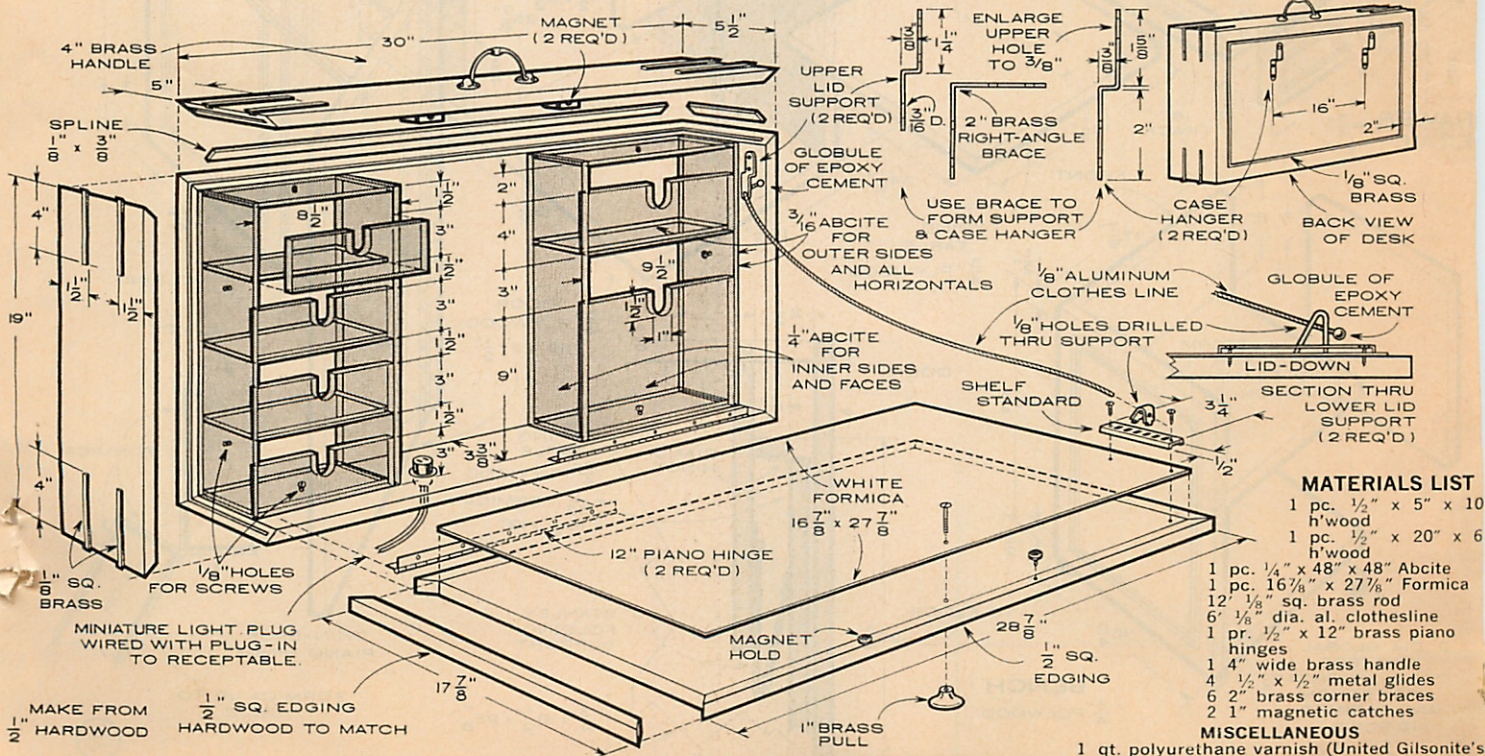

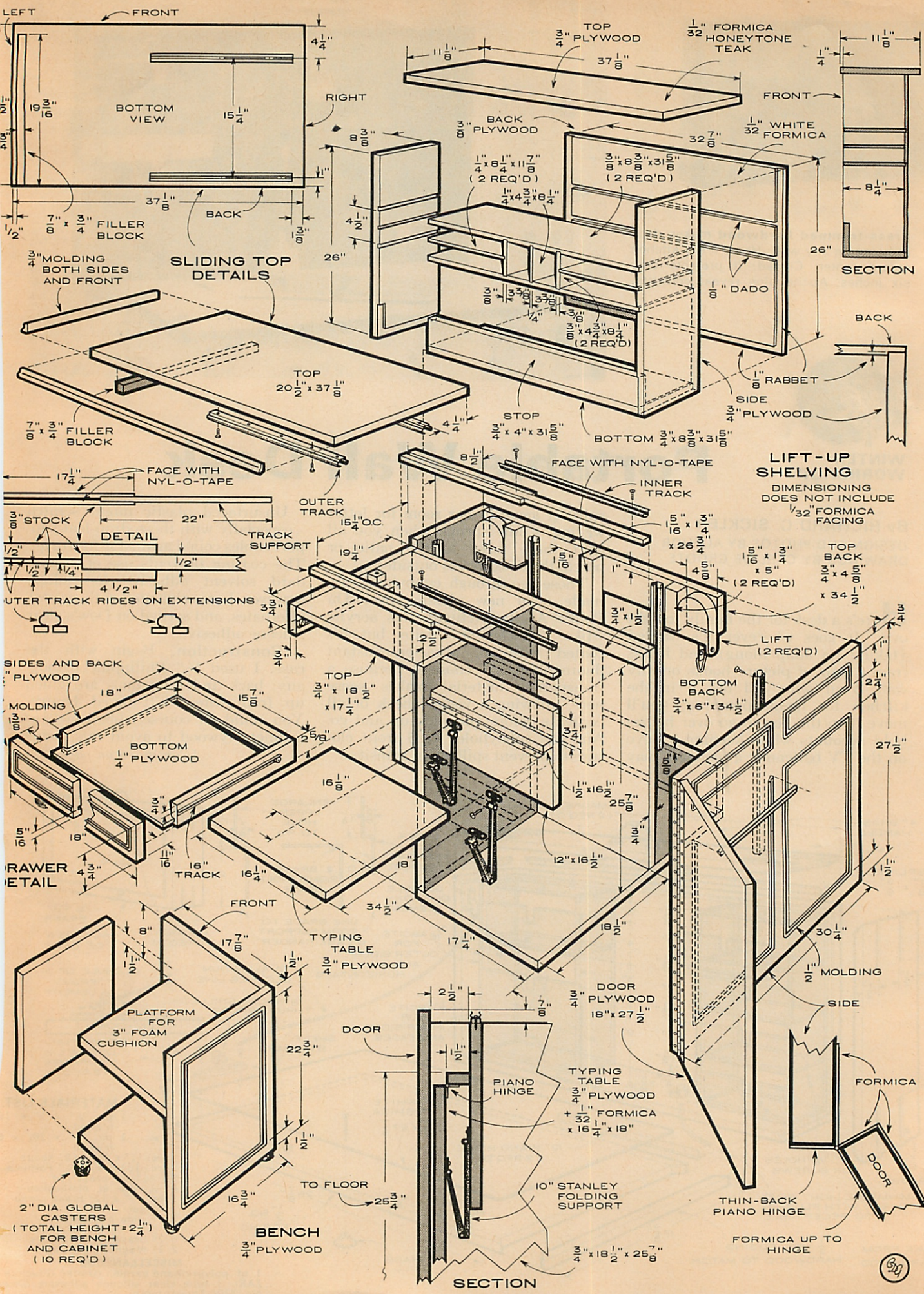

"Made \$300 a month in spare time."—H. Rivas, Los Angeles, Calif.
 "Cleared \$110 last Saturday."—R. M. Davis, St. Louis, Mo.
 "I hit \$125 in one week sparetime!"—V. Tizio, Brooklyn, N.Y.

Who else WANTS to be a LOCKSMITH?

Train FAST at Home. It's EASY Making Up to \$10 an Hour—even while learning!

If you enjoy fixing things, you're a "natural" to make hundreds of EXTRA DOLLARS A YEAR as a Locksmith. Need for service, sparked by rising crime, has never been so great and urgent. Easy, illustrated lessons complete with ALL practice equipment, personal assistance—PLUS professional tools and Key Machine given you free of extra cost—enable you to make \$5 to \$10 an hour... sparetime, or your own business. Hundreds we've trained are doing it.

Mail coupon for FREE facts—no salesman will call. Accredited Member Nat'l Home Study Council. Approved for Veterans.



BELSAW INSTITUTE
 1142 Field Bldg., Kansas City, Mo. 64111

BELSAW INSTITUTE
 1142 Field Bldg., Kansas City, Mo. 64111

Name _____

Address _____

City _____ State _____ Zip _____

Check here if eligible Veteran

Here's my quarter. Send the catalog and refund coupon. Dept. AL

Name _____

Address _____

City _____

State _____ Zip _____



Take the PS Plans Catalog And Get a Refund Too

Over 50 projects that you can build yourself. Send 25¢ today for the complete catalog, and we'll give you a 25¢ refund coupon good toward your plan order. Use the handy coupon above.

Popular Science Plans
 380 Madison Ave., New York, N.Y. 10017

Portable Wall Desk

[Continued from page 110]

the same splined-miter assembly. Before assembly—while panels can be handled flat—rout $\frac{1}{8}$ "-deep grooves for the brass trim. Note that the writing surface inside the drop leaf is faced with plastic laminate and framed with mitered edge strips. If you make those strips enough thicker than the panel to set flush with the Formica, you'll conceal and protect the laminate edges.

Abcite inserts. Size them for a snug fit. (I chose two thicknesses of Abcite, but this is optional.) For cutting, use a fine-tooth blade in a band, table, or jigsaw; for finger slots, I cut 1" holes on my drill press (1000-1500 rpm), completed them with two passes on my saw.

For square assembly, make the clamping jig shown. Cement fronts, bottoms, and one side of a unit at a time; clamp this in the jig for 24 hours, then slip the opposite side underneath after applying adhesive to all edges. To maintain contact, weight the unit (I used small cans of paint). Clean off excess adhesive with benzine or lighter fluid, wash with lukewarm water and detergent, polish dry with a soft cloth. Mount units inside the case with small brass screws through predrilled holes.

The hardware. Unable to locate hardware to support the drop leaf, I made my own. My cable is aluminum clothesline, but brass chain could be used; the upper supports are fashioned from brass angles bent in a vise. Each adjustable (and detachable) lower support consists of a short piece of slotted shelf standard plus one of the clip-in brackets sold with it. To close the lid, you can snap the clips from their slots to cross the cables inside.

The finish. It's especially important on a unit that is to be carried from place to place. I chose ZAR Satin Crystalite varnish, made by United Gilsonite. If your paint store doesn't carry it, use another good brand of polyurethane varnish.

Screw the modified-angle hangers on the back exactly 16" apart. Then, into every wall where the desk is to be positioned, drive a pair of heavy-duty picture hooks (the type that include an angled nail) aiming for the 16"-o.c. studs. Position these hooks so the bottom of the case will be just 30" from the floor.

I cut the cord of my high-intensity lamp near the base and attached a small female plug, which I mounted through the bottom of the case as shown. (You'll find them at any good electrical supply.) The extension cord stores in the desk. □ 3



Give old John something to shut him up.

Leaks. Squeaks. Whistles. Chances are, your toilet is trying to tell you it has a problem. An out-dated, corroded ballcock that leaks.

Now you can stop toilet noise once and for all. With Fluidmaster.

Fluidmaster eliminates the old-fashioned tank float and arm. And, because Fluidmaster operates hydraulically, it works with water pressure, for fast, positive shut-off.

Write today for full details. And give John the silent treatment.

Manufacturer of the Model 100, 200 and 400.



FLUIDMASTER, INC.
 1800 Via Burton
 Anaheim, Calif. 92805

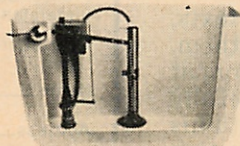

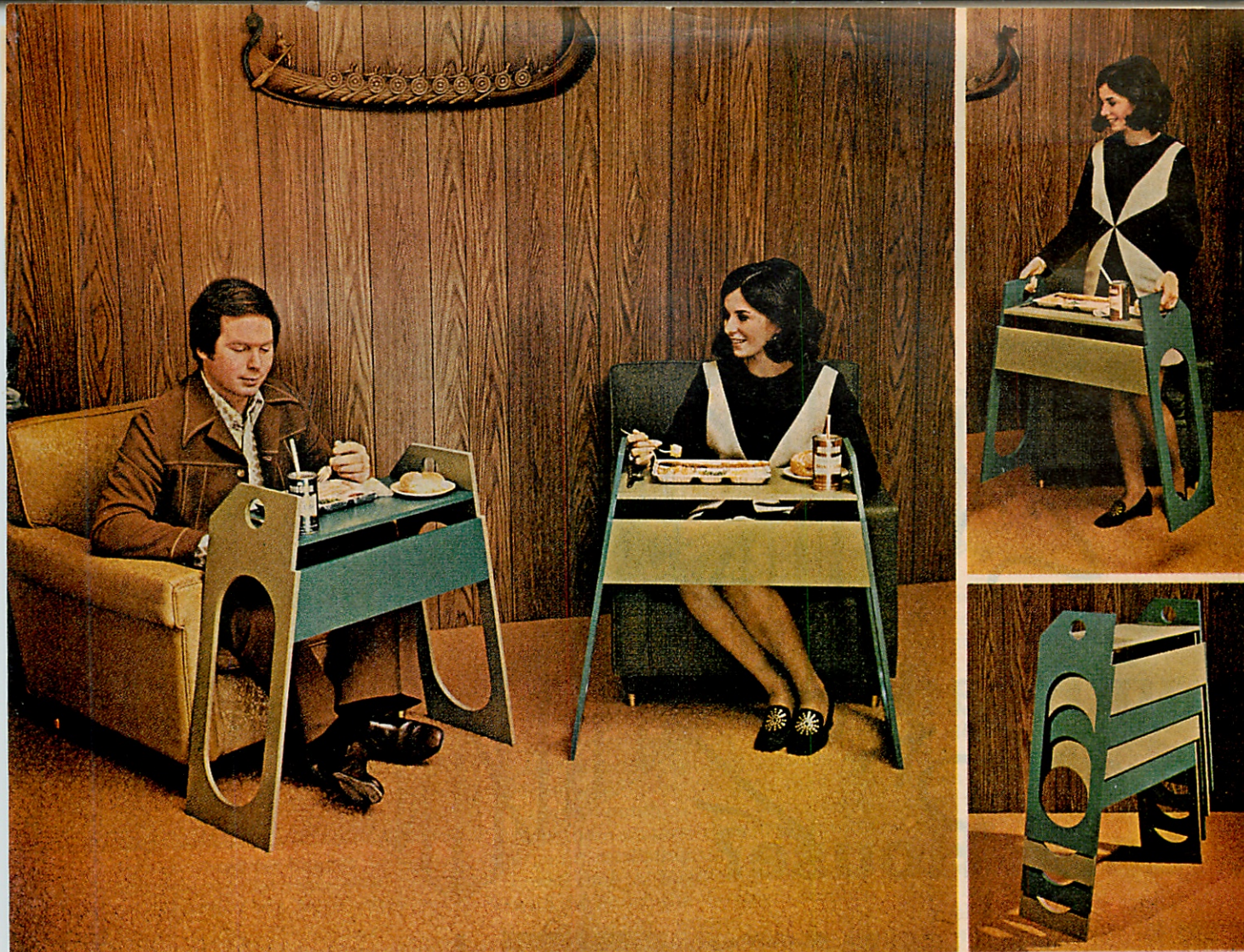

Whether for TV snacks or informal dining, these two-tone tables double as their own serving trays (top).

STACK SNACKERS: Easy to Build, Handsome to Store

Cut all four from a single sheet of 1/2-inch plywood, stack 'em up between uses

By ROSARIO CAPOTOSTO
DESIGNED BY LESTER WALKER

You wouldn't believe a quartet of such elegant, lightweight-but-sturdy tables could be cut from a single sheet of half-inch plywood. But the cutting diagram (next page) is as shrewdly designed as the tables themselves. We've never tackled a project that had so little waste.

And they store in a nontipping stack you won't want to hide in a closet—it's a trim piece of modern sculpture. The finger holes let you carry individual tables as food trays, but since the units are so light (and the projecting handles keep the tops spaced apart), you can easily lift a stacked pair with fully-laid place settings: just pick up by the side slots instead of the handles.

MDO plywood (medium-density overlaid both sides) is best, here. It has few internal voids, and the grainless surface is ideal for painting. Since you'll be using every edge of the panel, be selective—pick out one with undamaged corners.

You can cut the panel into handy

sizes with a portable saw, then work with a table saw to speed things up. Leave the leg panels paired up in twos until the large cutouts are done—it gives more solid area for clamping the straightedge guide. A drill-press circle cutter is best for the handle holes, though these could also be cut with your saber saw.

The inside faces of these panels require a shallow dado cut. To convert a straight dado for the angled assembly, bevel the top shoulder as shown in a sketch. This 8 1/2-degree bevel is a minute cut, so use a fine-tooth blade. (You'll want to use such blades for all cutting to minimize kerf waste.) Sand all pieces before assembling, in the jig, with glue and flathead screws; countersink heads for putty. When screws are tight, remove unit, wipe off excess glue, and start next assembly.

A quick-drying primer-sealer such as B-I-N works well on MDO. For our two-tone effect, we reversed panel colors on the second pair. Our paint was Ruberol Wet and Wild Semi-Gloss in custom olive and grass. Short-nap (bristleless) window brush for the edges minimizes runs.

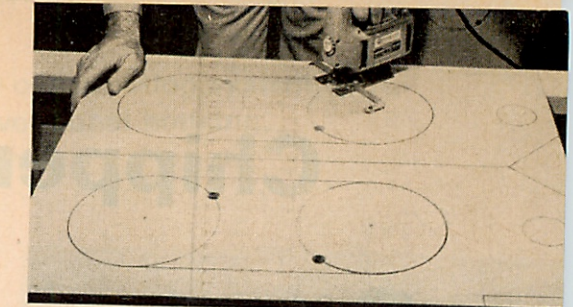
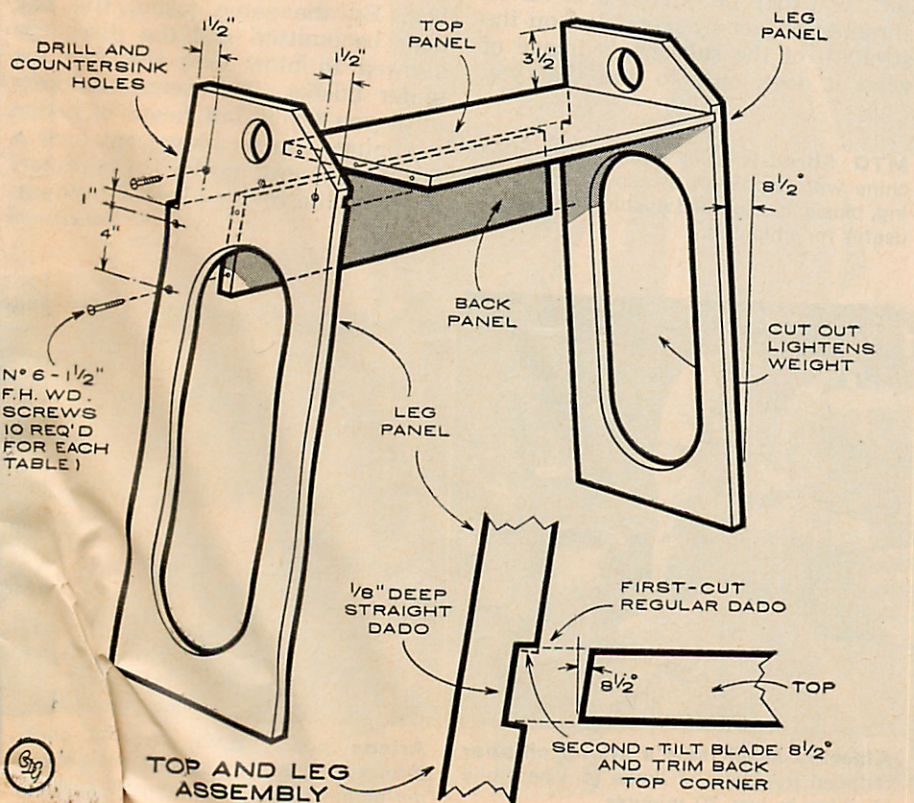
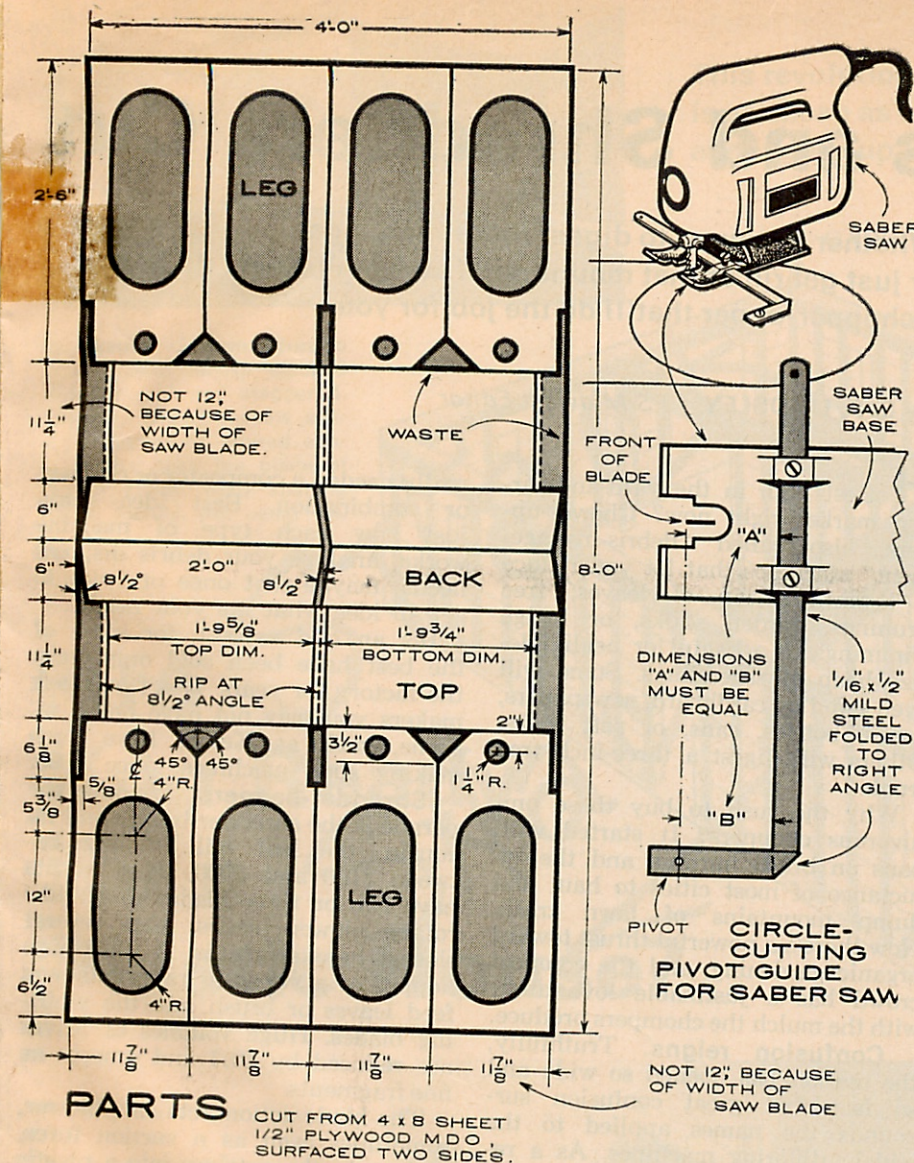

For end arcs of cutouts, bore entry holes in waste area and adjust pivot guide for 4-in. radius. Saw teeth must align with pivot point (sketch, left).

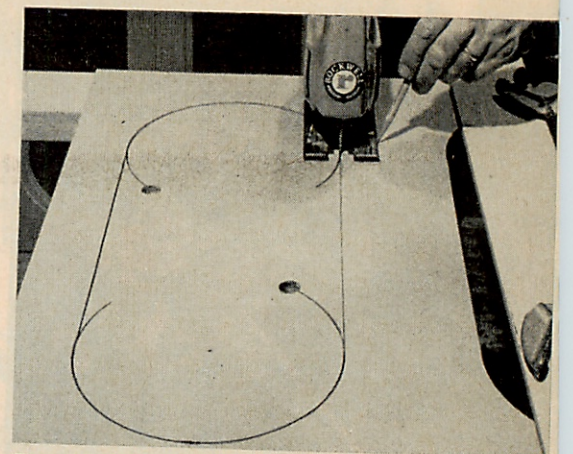

To cut straight sides, insert blade into kerf, move to exact tangent, and mark outside of base (above). Repeat at other end, clamp straightedge between marks.

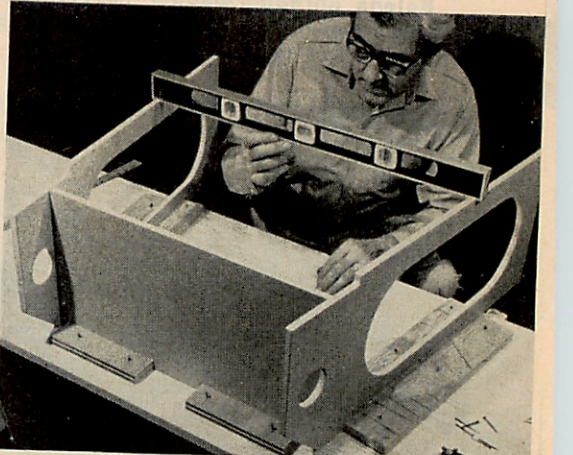

Assembly jig assures identical angles so units will stack. Fasten scrap blocks snugly against both faces of legs and top. Level checks for uneven work surface (use only for first assembly, shimming to level jig). Scrap clamped to back piece (below) positions it for drilling pilot holes through leg members and into its ends.

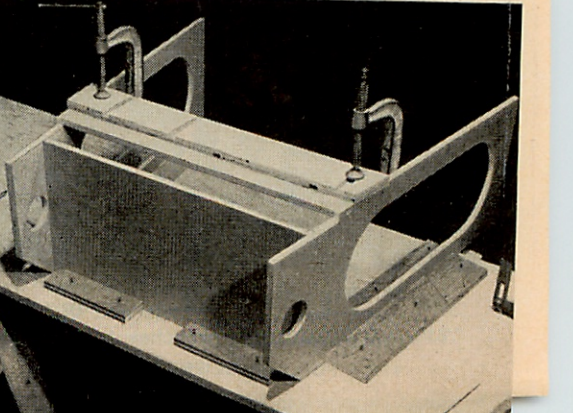

Modern Coffee Table to Brighten Living Room

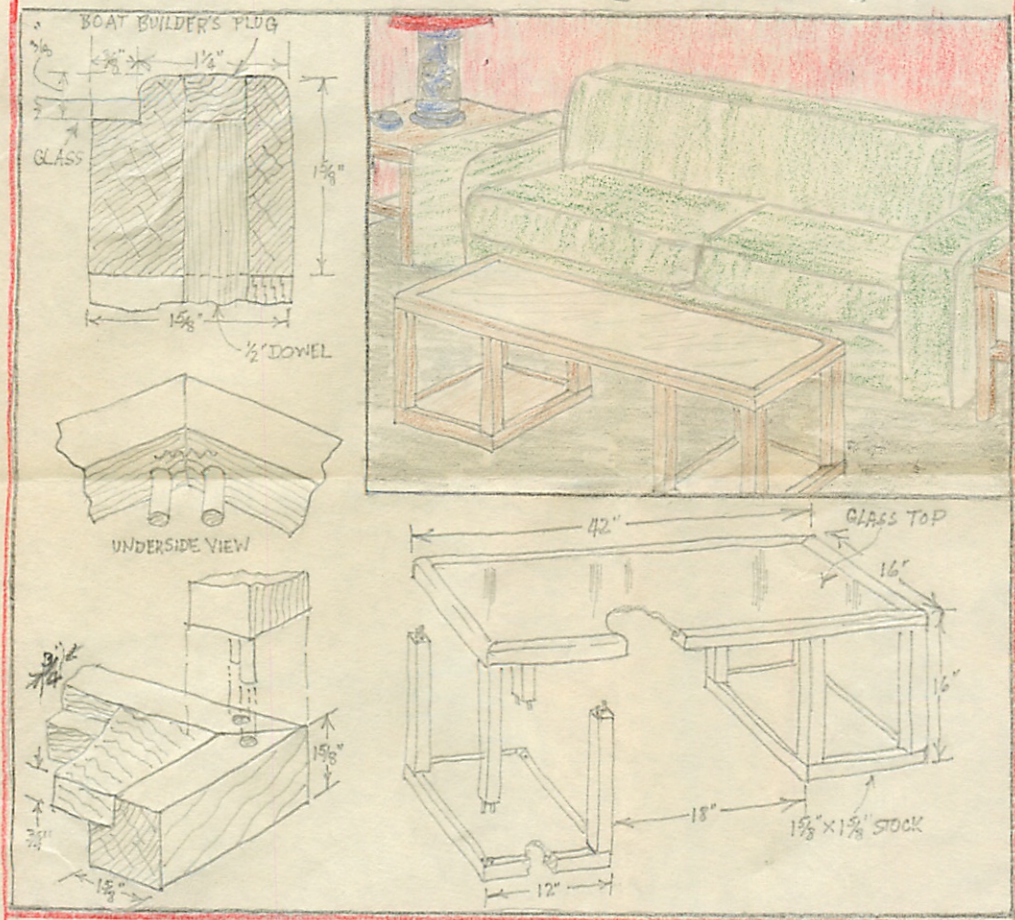

- 2 - 2" x 4" x 8" pine
- 1 - 4' x 4' x 1/2" mahogany
- 32 - 1/2" dowels
- 16 - 1/2" boat plugs

Featuring an attractive glass top that will never burn or stain, this handsome, open-design coffee table will fit practically any room containing modern furniture. The table is constructed almost entirely from 1 5/8 x 1 5/8-inch stock, while ply wood is used for a shelf at each base of the unit. After members of the top frame have been mitered and joined together, the pieces are rabbeted along the inside top edge to take 1/4-inch plate glass as indicated. The operation is repeated with each of the base frames in order to accommodate the shelves. All joints are secured with dowels and glue, while corrugated fasteners are driven into the underside of mitered corners for additional reinforcement. To attach the legs, two 1/2-inch holes are drilled through each corner of the top and base frames as well as the ends of each leg to receive dowels. After dowels are inserted in the holes in the top frame, boat builder's plugs are glued in place as shown, chiseled flush with the top side of the frame and sanded smooth. The entire unit is sanded thoroughly, given a coat of liquid sealer and, when dry, waxed or shellacked.

COPY

FROM POPULAR MECHANICS MAGAZINE — JANUARY 1953

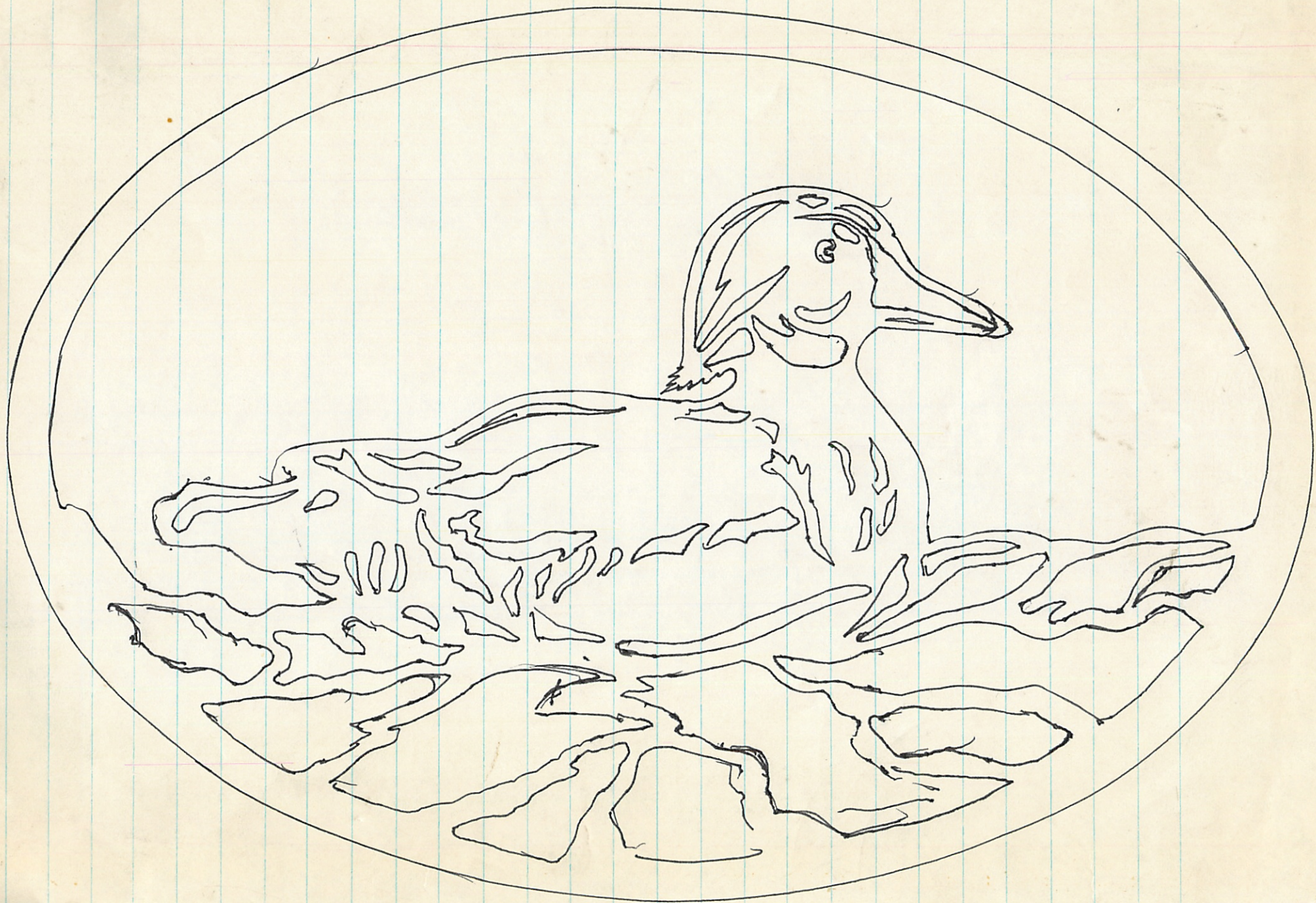

DOLL HOUSE

Approx: 24" wide
18" deep
18"-20" high

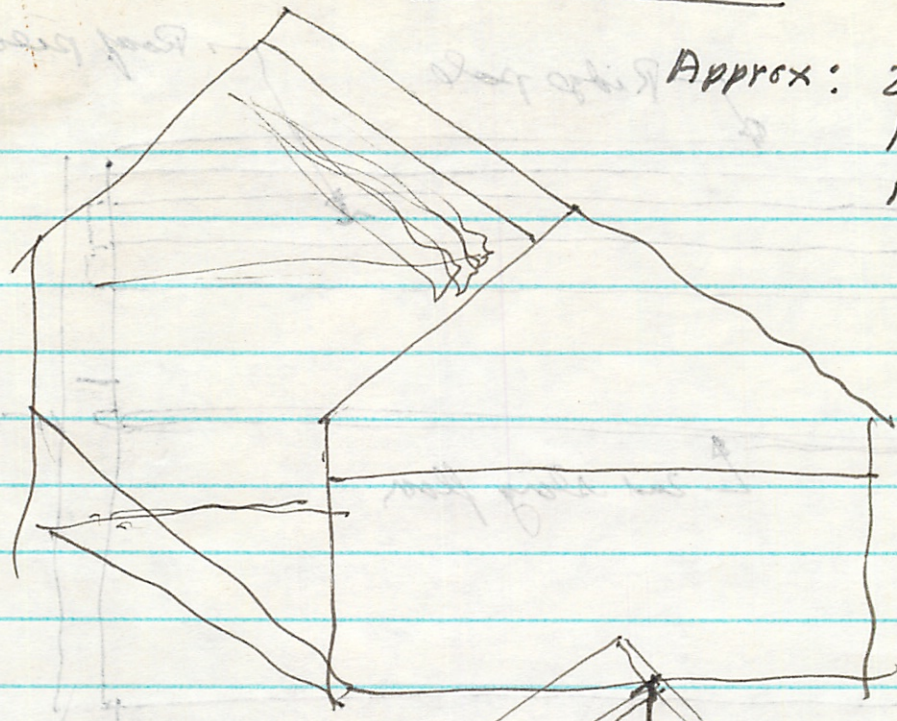

↓
Thickness
of frame
pieces
(square)
↓

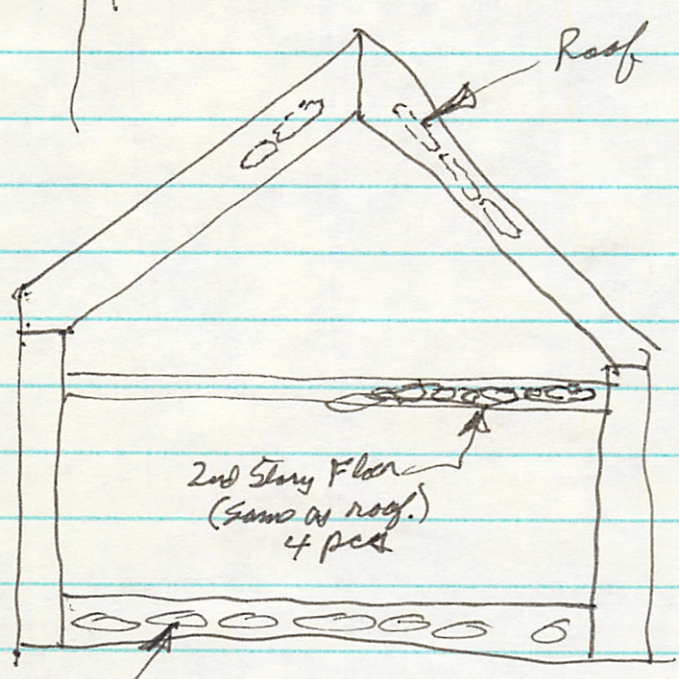
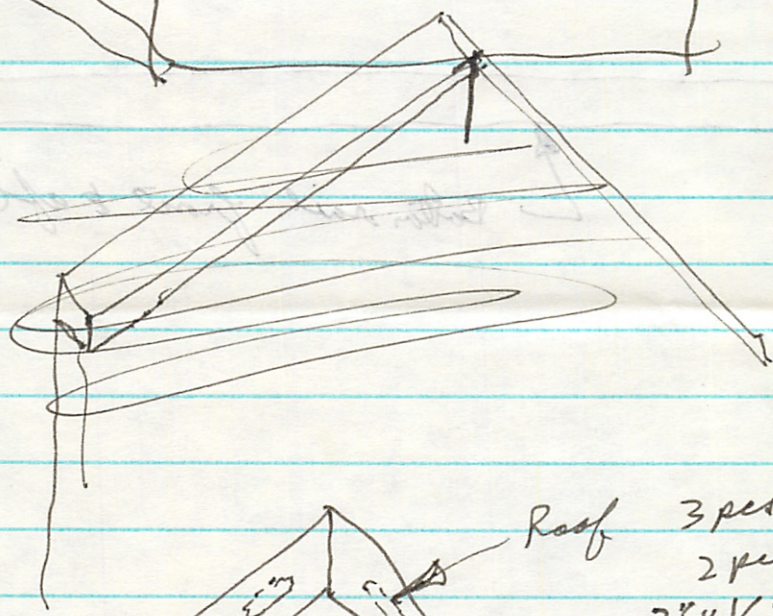

Roof 3 per rear.
2 per front
2" x 1/4"

2nd Story Floor
(Same as roof.)
4 per

Ballroom floor
(Full floor)

Ends (Pieces ~ 1/2" x 1/2" or 1/4" x 1/4")

DOLL HOUSE

Thickness of frame pieces (boards)
18" high
12" wide
5/4" wide

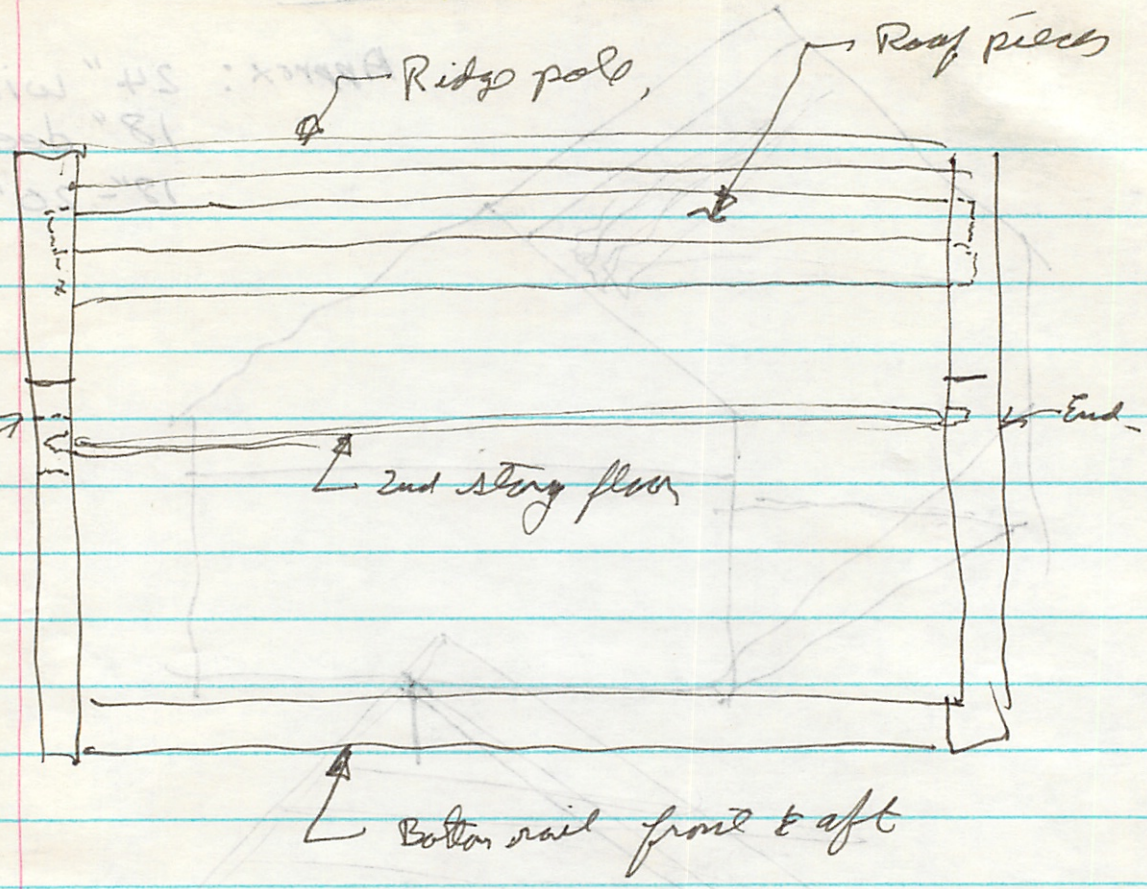

Roof 3/4" x 1/2" x 1/2"
5/4" x 1/2" x 1/2"
5/4" x 1/2" x 1/2"

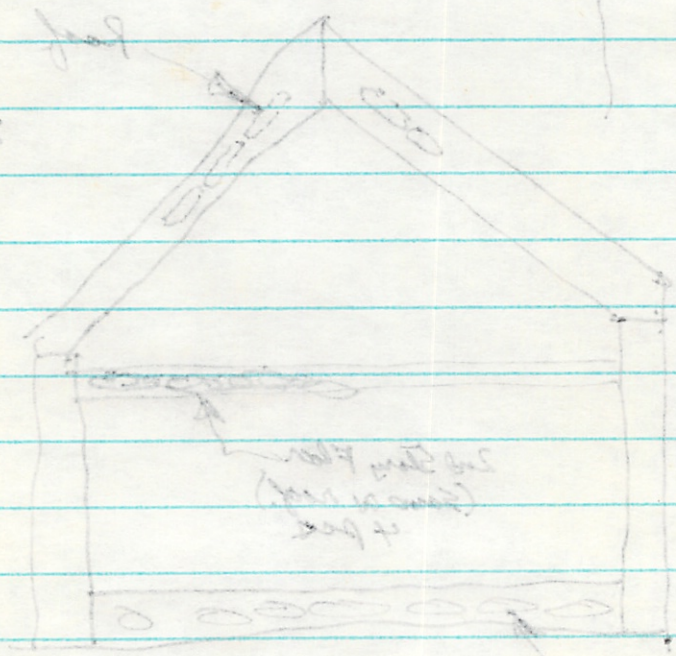

Ends (Pieces in 1/2" x 1/2" or 1/4" x 1/4")

1/2" x 1/2" (front floor)

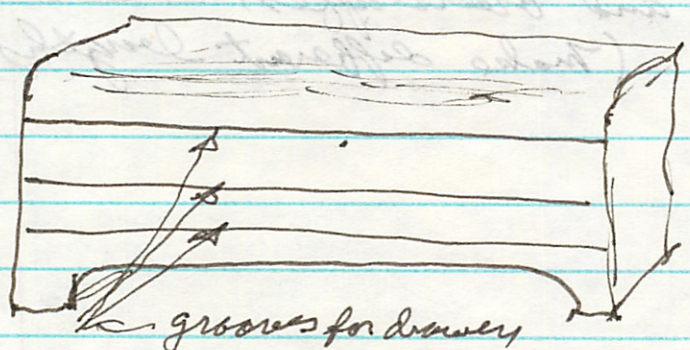
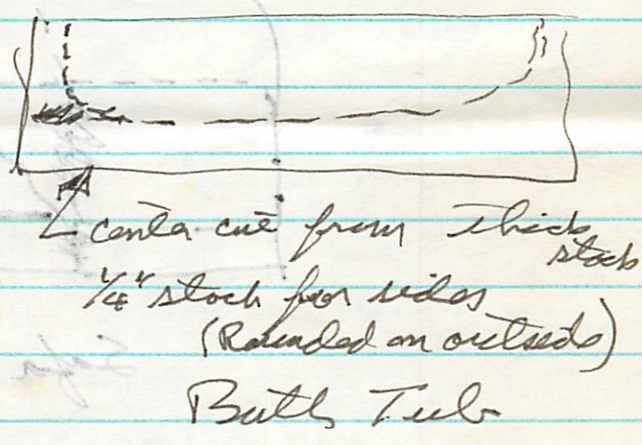
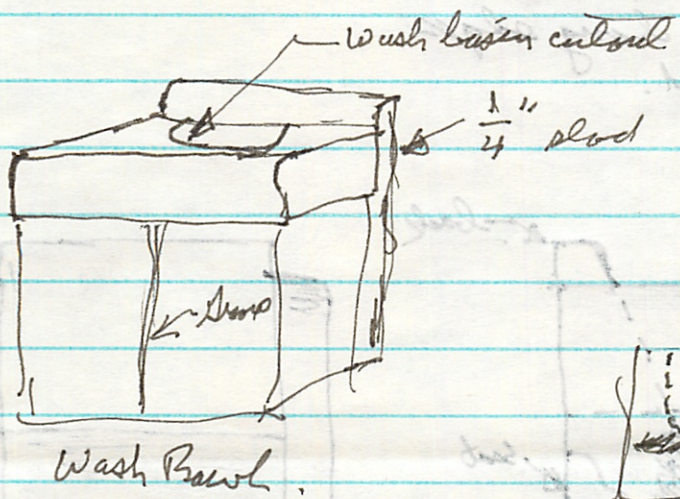
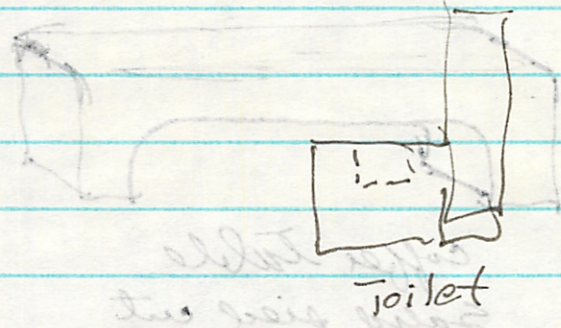
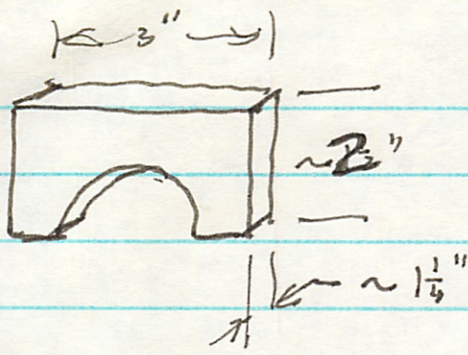

Chest of drawers
 or Buffet
 Cut from solid piece
 make different
 widths and heights.

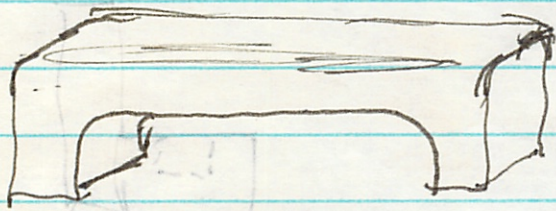

coffee table
Solid piece cut
out and long edges
rounded.

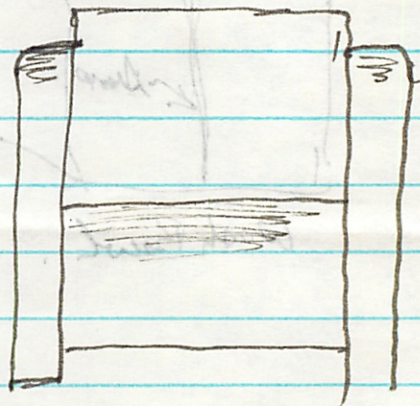
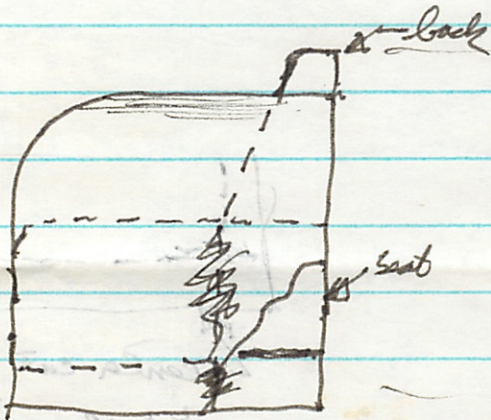

Sofa and overstuffed chairs
(make different lengths)

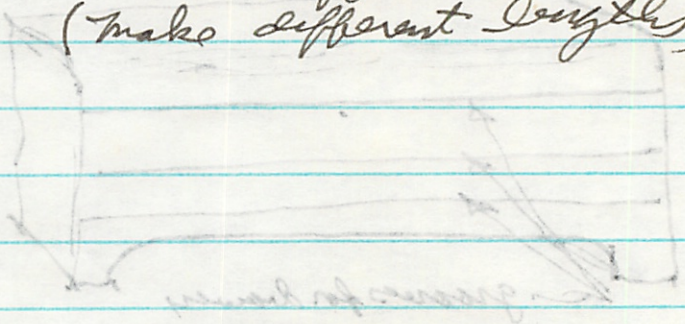

cut from solid piece
or buffet
cut from solid piece
make different
width and height

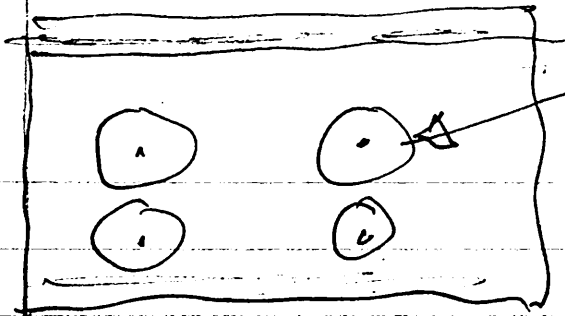

use bit to make learners.

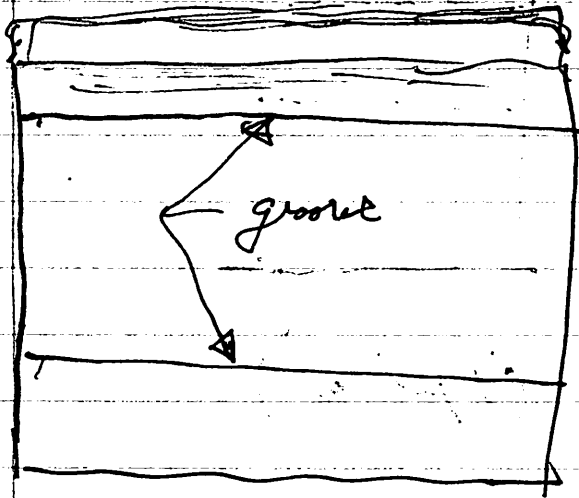

groove

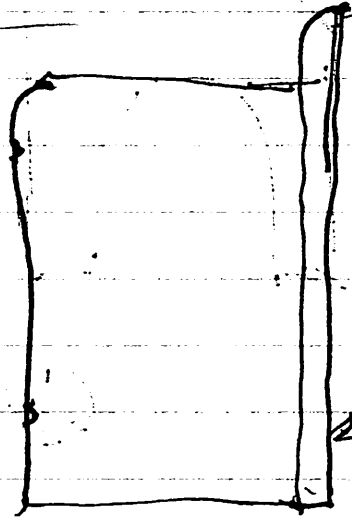

1/4" back

Range

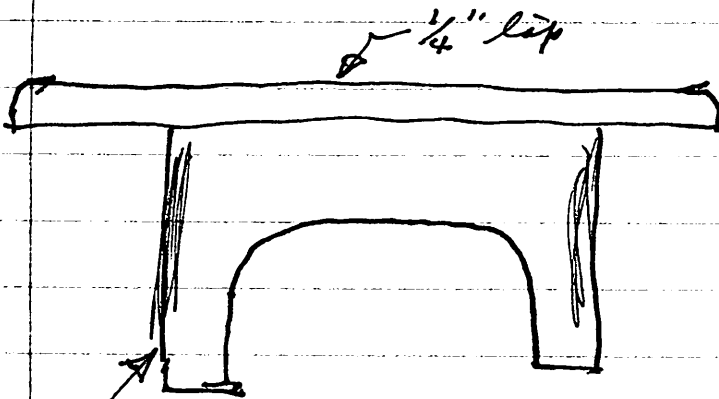

Legs.

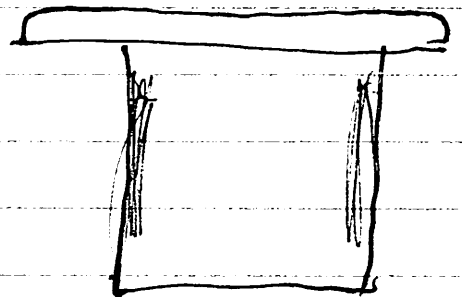
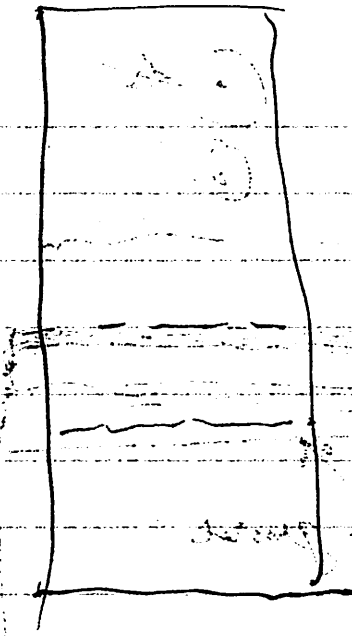
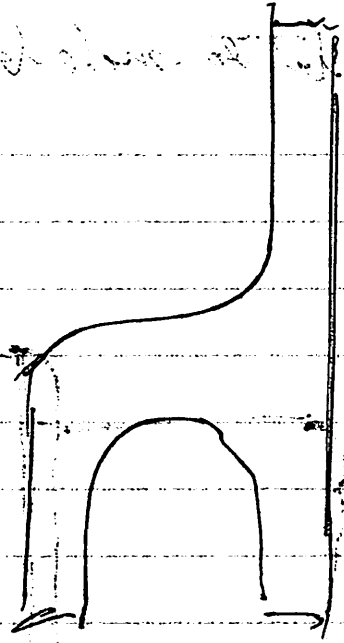
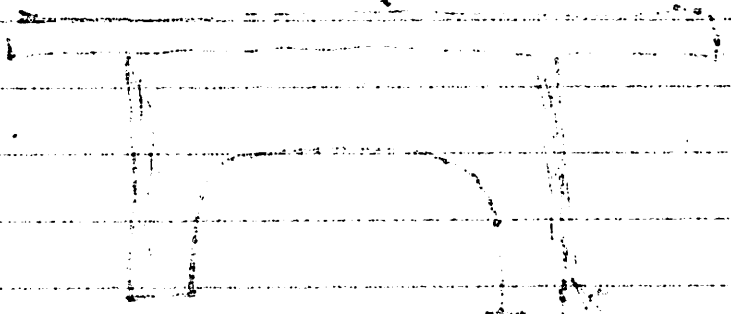
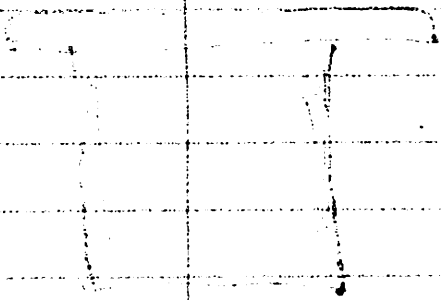

Table.



Chair (1 piece)



[Faint handwritten notes]

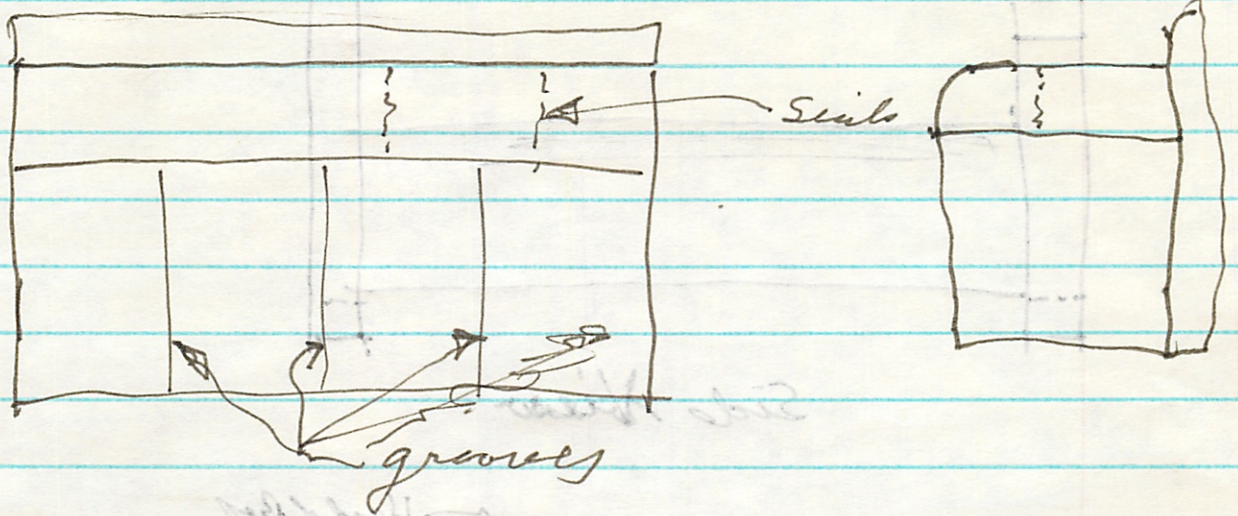

SINK

(Like wash bowl only
longer for drain board.)

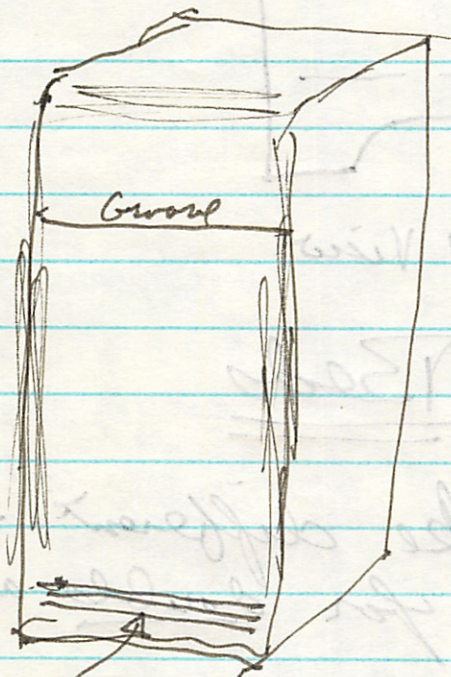

3 grooves for vent

Refrigerator

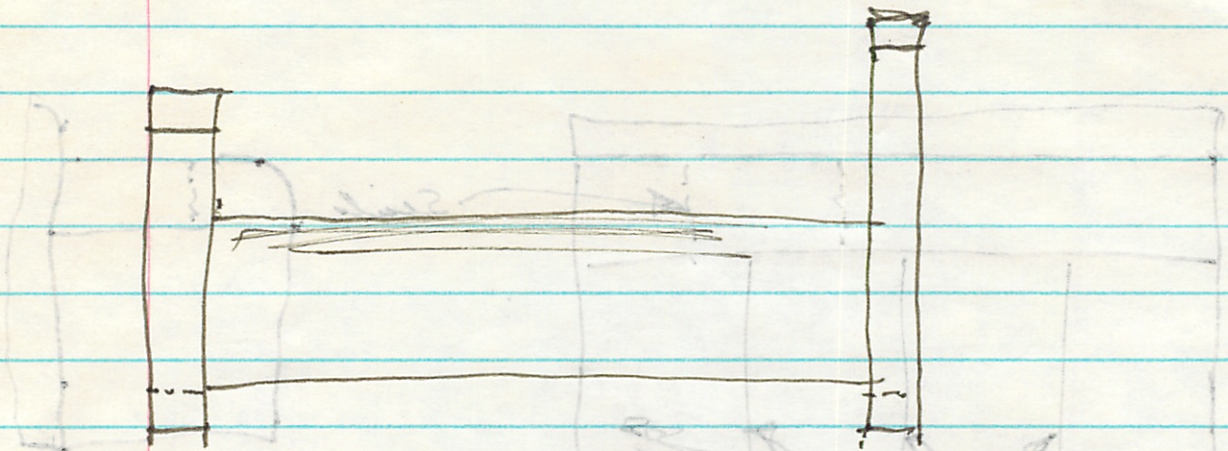

Side View

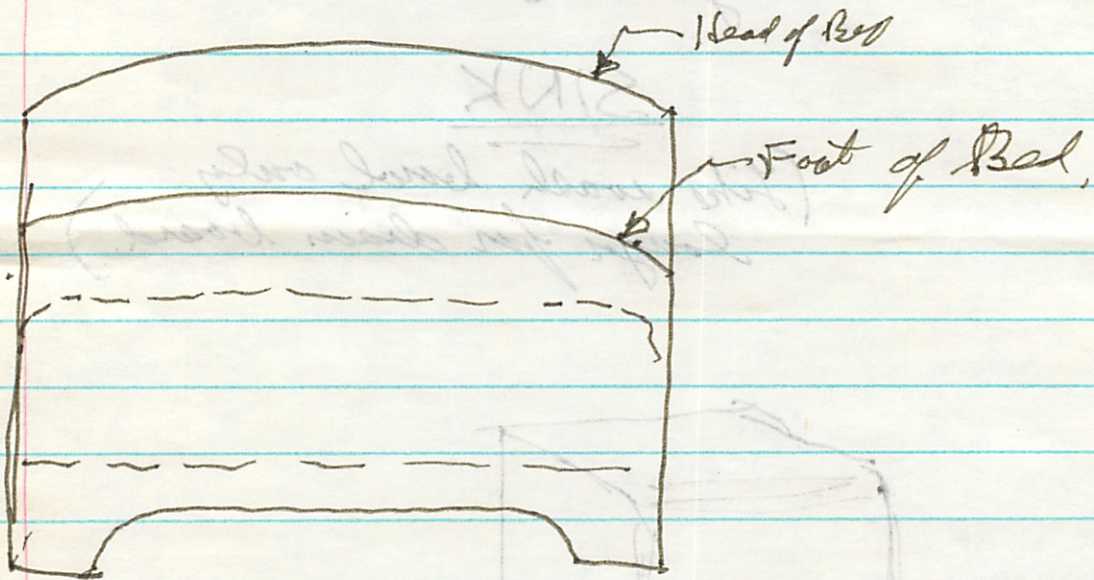

Head of Bed

Foot of Bed

Bottom End View

Beds

Make different widths
for double and twin

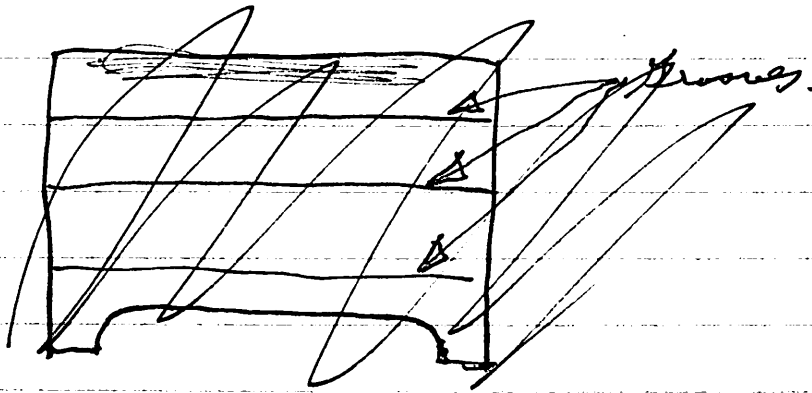

BR chest of drawers

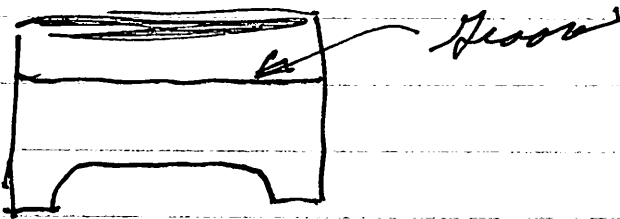

Bed Table

BED TABLE

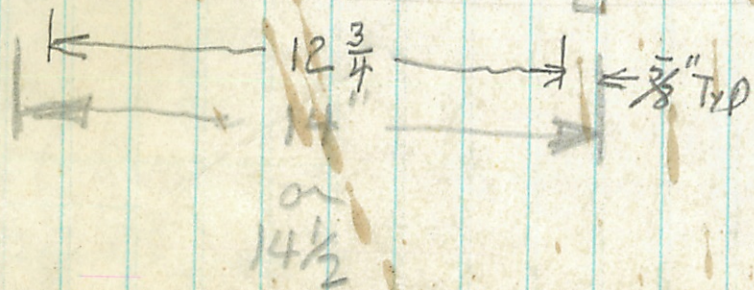
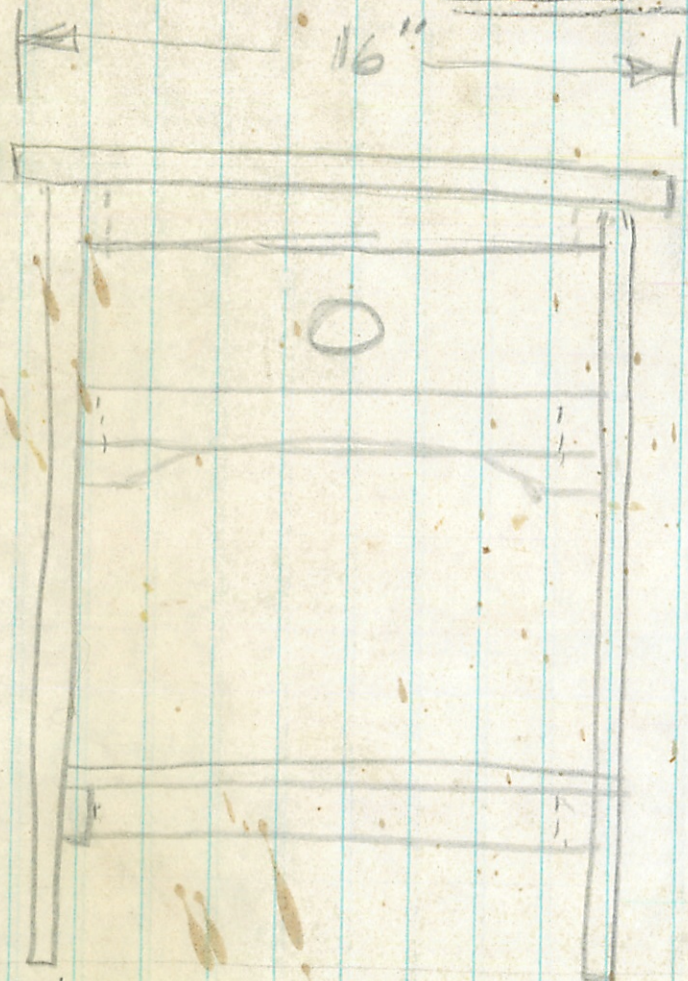

4 pcs $1" \times 12\frac{1}{2} \times 4'$

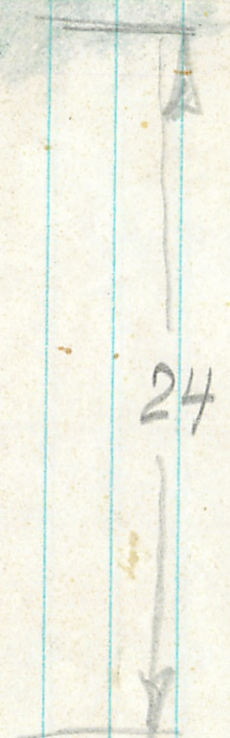
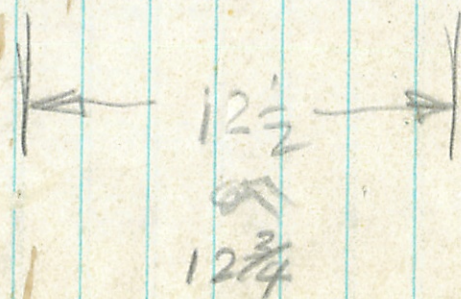

← 1" over base

← 3/4" over rug